



Installation Manual

RUBBERTOP
FLEECE



 FLEECE



Installation Manual

RubberTop Fleece

Preface

The information in this manual is a guideline to provide sound waterproofing. The base for the guideline is many years of practical and design experience obtained by SealEco. Local legislation or design practice may differ slightly from these specifications and instructions, however the information enclosed should be considered as a general guideline towards the most effective product use and application in a given situation when installing our membranes. Since the handling and installation is beyond our control, SealEco retains no responsibility for these areas. We make every effort to ensure that the information provided in this document is current and accurate. However, errors, misprints, inaccuracies, omissions or other errors may sometimes occur despite our best efforts. SealEco does not warrant that the content of this document including, without limitation, product-/installation descriptions or photographs and illustrations, is accurate or complete. RubberTop Fleece can only be installed after a successful training course. Please contact your local RubberTop Fleece supplier.

Table Of Contents

General Instructions	4
List Of Materials	6
Vapour Barrier	6
RubberTop Fleece E	6
Protection Layer - Non-Woven Polyester	6
Adhesives - Cleaner - Sealant	6
RubberTop Fleece E: Tape Accessories	8
Tools, Machines And Other Accessories	9
Work Preparation - Quality Assurance And Control	10
Preparation Of The Workspace	10
Materials Handling And Storing	10
Climatological Circumstances	10
Oxidisation	10
Quality Assurance And Control	11
Roof Build-ups	12
RubberTop Fleece Adhered	12
RubberTop Fleece E Mechanically Fastened	12
RubberTop Fleece Ballasted	13
RubberTop Fleece Green Roof	13
Refurbishment Requirements	13
Splicing	15
Tape Splicing Technique	16
Horizontal Installation Of RubberTop Fleece	29
RubberTop Fleece Adhered	29
RubberTop Fleece Mechanically Fastened	35
RubberTop Fleece Ballasted	36
RubberTop Fleece Green Roof	38
Base Tie-In	40
Mechanical Fastened Base Tie-In RubberTop Fleece	41
Adhered Base Tie-In RubberTop Fleece	42
Upstands	44
Upstand With Cold Splicing Technique	44
Upstand With Adhered Base Tie-In	45

Internal Corners	46
Internal Corners With Mechanically Fastened Base Tie-In	46
Internal Corners With Adhered Base Tie-In	49
External Corners	52
External Corners With Mechanically Fastened Base Tie-In	52
External Corners With Adhered Base Tie-In	55
Drains	57
Drains With Splicing Tape Technique	58
Pipe Penetrations	60
Flashing Tape Pipe Boot	60
Roof Edge Details	64
Connections To Walls	65
Roof Edge Terminations	67
Connections To Gutter	69
Expansion Joints	70
Green Roof Edge Detail	72
Supervision And Maintenance	73

1 General Instructions

Substrate

RubberTop Fleece can be used on all common roof constructions such as: concrete, timber or corrugated metal deck. Concrete or timber decks can be used for cold roofs without insulation but on metal deck, insulation is required. Do not allow any remaining condensation in your substrate. It is the responsibility of the roofer to choose the correct roof design, taking into account all the roof parameters and desires from the customer and architect.

The roofing substrate should have adequate strength and rigidity to carry actual loads from wind, snow, ballast, solar panels. We recommend a minimum slope of at least 2%. However it should be noted that neither RubberTop Fleece, nor its splicing techniques are influenced by ponding water.

The substrate should be relatively even - equivalent to wood floated concrete. It should be clean and free from water in any form as well as contaminations such as oil or grease. Note also that foaming agents present in cellular concrete might influence ageing properties of the RubberTop Fleece membrane. Screws or nails must be properly entered into substrate without risking coming out.

The smoothness of the substrate is particularly important under splice areas. Difference in levels of more than 5 mm must be levelled before splicing.

Vapour Barrier

When installing a warm roof, a suitable vapour barrier must be applied under the insulation and it should be installed to be air tight over the entire surface. When possible, SealEco recommends the use of an Alushell vapour barrier.

At roof terminations, and connections to walls, the vapour barrier should be brought up over the thermal insulation. At penetrations, the vapour barrier should be connected airtight to prevent convection and condensation.

Insulation

RubberTop Fleece can be installed upon different types of insulation without risk of migration. The chosen insulation must be suitable for low slope roofing and adapted to the requirements of the roof design. Insulation should have a compression strength at 10% deformation of minimum 60 kPa (60 kN/m²) to ensure a proper installation. Ensure all local legislative requirements are met.

Install only insulation suitable for the roof in accordance with the guidelines of the supplier.

Polystyrene insulation can be damaged by the solvents of adhesives and primers. For this reason we recommend that the insulation is covered by a protecting layer such as an extra layer of RubberTop Fleece, a mineral wool board or bitumen felt around details.

Make sure to control that the chosen insulation is suitable for adhesives when making securement with adhesives. In case adhesion on naked EPS or MW is needed, please contact our technical department. EPS with a facer can be used when tests are available and allowed by the producer.

Keep Contact Adhesive 5000, Spraybond E245, Spray Contact Adhesive P125, Single Ply Primer, Cleaning Wash 9700 and PUR Adhesive 3200 away from insulation that cannot resist solvents.

2 List Of Materials

All Technical Data Sheets and Safety Data Sheets can be consulted on our documentation app on www.sealeco.com. Availability depending on country. Contact your local supplier for more information.

2.1 Vapour Barrier

AluShell is a high-quality self-adhesive air and vapour control layer composed of a reinforced aluminum foil, a self-adhesive layer of high polymer SBS and a silicone protective film. Due to its high resistance to water vapour permeability, AluShell can be used for almost all flat roofs in combination with most indoor climate conditions. AluShell is available in two thicknesses 0.4 mm and 0.6 mm. AluShell 0.4 mm can only be applied in mechanically fixed roof applications.



2.2 RubberTop Fleece E

RubberTop Fleece E is an elastomeric EPDM membrane for roof waterproofing that is reinforced with a fleece backing. It is provided with a free edge for cold seam splicing. All tape accessories can be spliced on this membrane. It can be secured to the roof by mechanical fixation alternatively be adhered with PUR-adhesive, MS Polymer paste adhesive

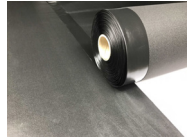

or contact adhesive. There are two different qualities of the RubberTop Fleece membrane: S (Standard) and FR (Fire Retardant). The decisive factor when choosing product alternative is the required external fire classification. Because of the continuous testing and changes in insulation we recommend to contact our Technical Department for the actual allowed roof build ups.

RubberTop S is an elastomeric waterproofing membrane based on the rubber polymer EPDM. SealEco provides a range of different widths in RubberTop S which can be used to cover the parapets.



2.3 Protection Layer - Non-Woven Polyester

Non-woven polyester textile used for membrane protection.



2.4 Adhesives - Cleaner - Sealant

Cleaning Wash 9700 is a technical petrol used for cleaning weathered rubber membranes before installation and repair.

Coverage: 5 - 20 m² depending on the substrate



Contact Adhesive 5000 is a ready-for-use contact adhesive for adhering EPDM and Butyl membranes to horizontal and vertical substrates.



Coverage: 500 g/m²

E245 Spraybond is a sprayable contact adhesive with a fast drying formula of synthetic polymers and solvent, which by means of propellant gas with constant pressure, is made sprayable without the help of electricity and compressor. Read and follow instructions for usage prior to use.



Coverage:

General use: 200 g/m² - Fleecebacked membranes: 450 g/m²

Handgun



Extension 61 cm



Hose



Adapter E17



Cleaner E17



Spray Contact Adhesive PI25 is a contact adhesive to be applied with spraying equipment. Air pressure tools (compressor, electricity, hoses) are needed. Consult TDS and MSDS before use.



Coverage:

General use: 300 g/m² – Fleecebacked membranes: 450 g/m²

Pressure Vessel



Ecobond is an environmental friendly MS polymer based adhesive for adhering SealEco EPDM on horizontal and vertical surfaces like wood, concrete, metals (zinc, aluminum and steel) and bitumen. Ecobond is available in two versions, one for horizontal applications (Ecobond H) and one for vertical applications. (Ecobond V)



Coverage: 340 - 650g/m² for partial adhesion, 1100g/m² for full adhesion

Paste Applicator 600ml



Gun Ecobond 2800ml



Accessories



Primer 9800 is a polymer based primer for consequent use with self-adhesive SealEco rubber membranes, and for priming porous substrates.

Coverage: 125-250g/m² depending on substrate



Pur Adhesive 3200 is used for adhering fleece backed SealEco membranes on different substrates. Due to its special formulation, in which physical drying and chemical cross linking have been combined, the adhesive is not readily absorbed into materials and provides good surface adhesion.

Coverage: 350 g/m²



Sealant 5590 is a neutral, elastic one-component joint sealant based on silicones. It has excellent adhesion to SealEco rubber and most substrates. The sealant is used for sealing details, repairs or sealing against substrates.

Coverage: 6 lm/cartridge - 12 lm/sausage



2.5 RubberTop Fleece E: Tape Accessories

Single Ply Primer is used to prime SealEco membranes to provide a good adhesion between Seam Tape, Flashing Tape or Cover Tape and SealEco EPDM membranes. It can also be used to prime substrates such as concrete, plywood, OSB and metal.

Coverage: 200 g/m²



Scrub Held Handle



Scrub Pad



Seam Tape is used for joining two panels of SealEco EPDM together. The product is durable and flexible and provides immediate adhesion when in contact with the membrane. Seam Tape should always be used in combination with Single-Ply Primer.

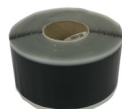

Cover Tape is used for connecting and joining SealEco EPDM membranes. Cover Tape is mainly used for splicing mechanically fixed membranes, securing roof edge trims, repairs and details. Cover Tape is flexible and provides immediate adhesion when in contact with the membrane. The product should always be used in combination with Single Ply Primer.



Flashing Tape is used for sealing details, corners, pipes and T-splices on SealEco membranes. The tape provides immediate adhesion, is extremely flexible and can be shaped to seal irregular details. Flashing Tape should always be used in combination with Single Ply Primer.



The **Self-Adhesive PE drain** is a roof drain equipped with a collar of self-adhesive Cover Tape that makes it directly installable to the membrane. The drain can be used horizontally as an overflow. The pipe is made of polyethylene.



The **EPDM PE drain** is a roof drain equipped with a collar of EPDM. The drain can be used horizontally as an overflow. The pipe is made of polyethylene.



2.6 Tools, Machines And Other Accessories

Grinding Machine Flex for refreshing oxidised rubber surface before splicing. The machine is delivered with adaptation rings to fit the width of the grinding disc.



Accessories

Silicone pressure roller 40 mm



Silicone pressure roller 80 mm



Silicone pressure roller Leister 40 mm



PTFE roller Leister 28 mm



Brass detail roller



Brass detail roller Leister



Reinforced EPDM scissors



Protection tape



RBS 50 washer



Pressure plate 40x80 mm



Pressure plate round Ø50 mm



Alu wall profil



Battenbar 30 mm x 3 m

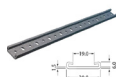

i Availability depending on country. Contact your local supplier for more information.

3 Work Preparation - Quality Assurance And Control

3.1 Preparation Of The Workspace

The basis of an efficient and safe roof installation is preparation and careful planning of the work. The roofing work as well as quality assurance becomes easier and more secure if there is a way to split the roof into smaller areas that can be finished in detail during each working period.

3.2 Materials Handling And Storing

Check upon delivery that the materials match the order acknowledgement, shipping documents and product labels. Missing or damaged goods should be reported immediately. Store all materials according to the product specifications.

Packages shall not be opened until the material is to be applied. If the installation work is interrupted, unprotected rolls should be covered or put back in their packaging.

Make sure that the substrate can carry the load when material is placed on the roof (point load).

Do not allow traffic or work by other contractors until installed roof areas are satisfactory protected. Keep the work site in good order and free from construction debris, loose nails, metal pieces, etc.

3.3 Climate Conditions

When adhering RubberTop Fleece, or using Single Ply Primer and Tape splicing, the minimum temperature is +5°C. Even in case of precipitation, mist or risk of condensation, Tape splicing and use of adhesives will be stopped immediately.

The polyester backing of RubberTop Fleece is highly capillary, which will absorb a lot of water. This will have a negative impact on the substrates and splices.

3.4 Oxidisation

When RubberTop Fleece is exposed to the sun for a longer period the surface oxidises. This does not affect the properties of the membrane itself but it will have an impact on the quality and strength of the RubberTop Fleece splice. We therefore recommend careful planning so that all splicing is done as soon as possible after RubberTop Fleece is rolled out and fixed to the substrate. Another alternative is to cover the seam areas or to fold back the membrane to protect them, until splicing can be fulfilled according to the instructions. It is of particular importance to perform a splice test before starting regular splicing.

3.5 Quality Assurance And Control

Quality control and assurance are essential elements in the installation of RubberTop Fleece Roofing System.

As the quality of the waterproofing is highly dependent upon the workmanship of the installer, installation is only permitted by contractors that are trained and certified by SealEco or a Registered Partner.

Documentation

Each installation should be carefully documented and include data on the installed membrane.

Visual Control

Visual controls of the work and the quality should be carried out throughout roof installations. Problems and faults should be detected and fixed as early as possible. Controlling aspects should be:

- That the correct materials are being used and installed with the correct equipment, and ensuring proper on-site storage.
- That the materials are installed according to the guidelines of SealEco, local regulations and in accordance with good workmanship practice.
- That the material is not at risk of mechanical damage.

4 Roof Build-ups

i Information about installation, see chapter 6: Horizontal Installation of RubberTop Fleece.

4.1 RubberTop Fleece Adhered

Figure 1

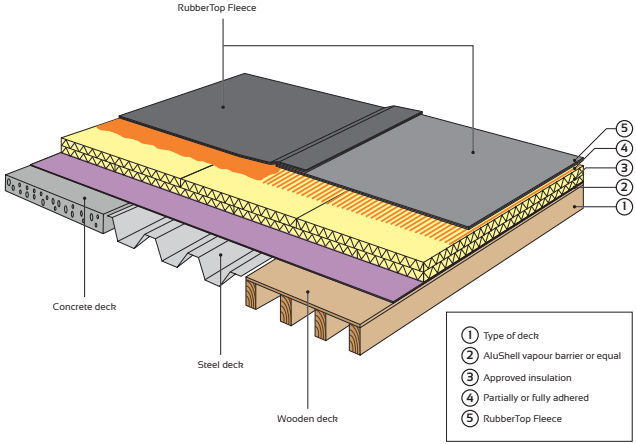

4.2 RubberTop Fleece E Mechanically Fastened

Figure 2

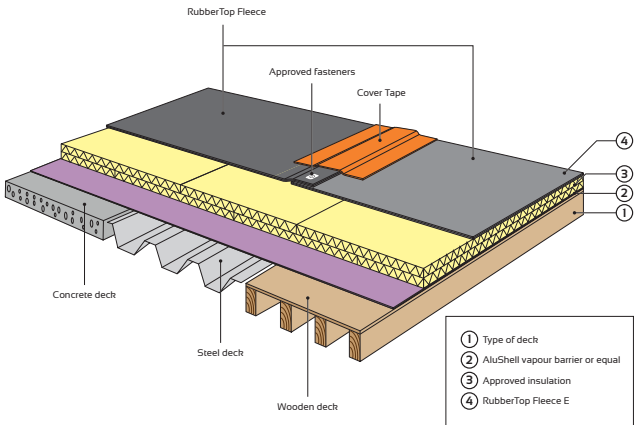

4.3 RubberTop Fleece Ballasted

Figure 3

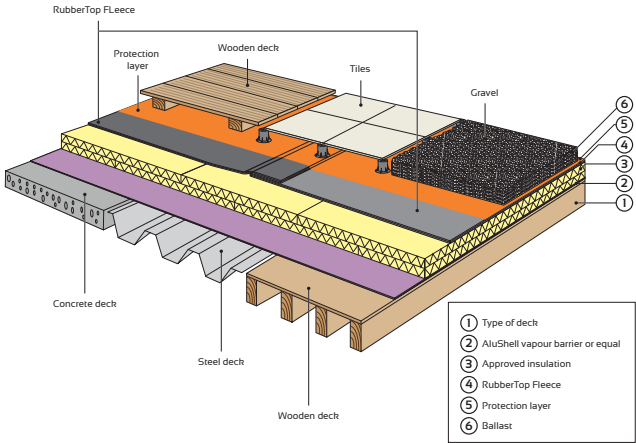

4.4 RubberTop Fleece Green Roof

Figure 4

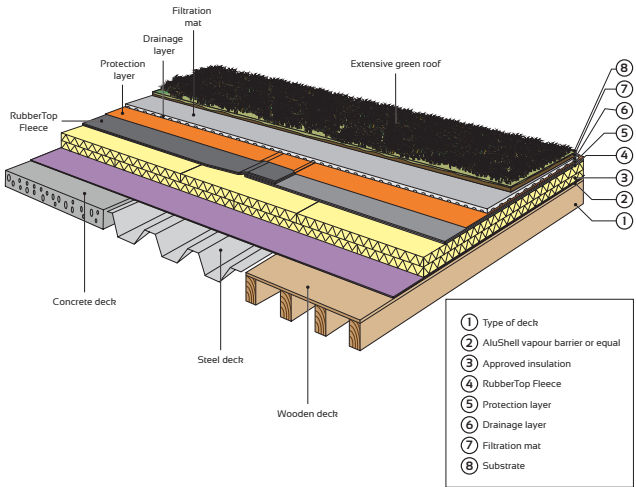

4.5 Refurbishment Requirements

Before initiating a refurbishment of a roof an investigation should be performed. This should include finding the reason for the refurbishment and if some circumstances have led to a shorter life span of the waterproofing than expected.

It is also important to evaluate which components of the roof can be reused and which need to be changed. Do also check the condition and installation of the vapour barrier especially around details.

When connecting to an existing membrane other than RubberTop Fleece or RubberTop, a curb detail should be constructed. Both the RubberTop Fleece and the other membrane should be terminated at the top of the curb and be covered by suitable coping.

EPDM

No specific action needs to be taken. Only inspection and treatment of troubled areas needs to be attended to, such as; sharp edges from metal details, nails and screws not properly entered into substrate etc. It is not possible to adhere a RubberTop Fleece as refurbishment to an old EPDM membrane. We only guarantee connections to SealEco EPDM membranes. All instructions need to be followed.

BITUMEN

Old bitumen felt roofs must be swept clean, sealed and levelled. Stones and sharp objects should be removed i.e. with a steel scraper.

PVC

During renovation of PVC roofs we recommend that the old PVC should be removed from the roof. A minimum requirement is that the PVC is cut loose at perimeters, at details and in sections over the roof. Keep in mind that PVC tends to shrink and have an impact on the installation of the EPDM membrane.

It is not possible to adhere a RubberTop Fleece as refurbishment to an old PVC membrane.

5 Splicing

For the onsite seaming during the installation, cold splicing technique is applied.

Cold splicing with Seam Tape technique can be used for seams and detailing.

Product availability depends on the country.

Following instructions have to be followed at all times:

- The membrane shall be dry and clean. If not dry and clean, the membrane should be cleaned with Cleaning Wash 9700.
- Don't use other products for cleaning, because they might interfere with the splicing techniques or be incompatible with RubberTop Fleece.
- Be sure that no moisture is under the membrane, or in the fleece backing. This will have a huge impact on the strength of the splice and adhesion to the substrate.
- In case of precipitation all splicing will be stopped immediately.
- Never make splices when membrane is stretched. All tension should be removed.
- Folds in splicing are not permitted.
- All membranes installed should be spliced the same day. Prevent water coming into contact with the fleece backing, because of its high capillarity. Moisture that is in contact with the fleece will condense under the membrane.
- As the RubberTop Fleece is exposed to sun and weather conditions, the surface oxidises. This does not change the properties of membrane however the quality and strength of the splice is strongly affected. Therefore we recommend careful planning so that all splicing is done as soon as possible after RubberTop Fleece lay-out. Another alternative is to cover the seam areas or to fold the membrane to protect seam areas. If the RubberTop Fleece has oxidised, the splice areas must be ground with a grinding machine and nylon grinding disc followed by cleaning. The time it takes for oxidisation to start depends on the strength of the sun. Therefore it is of particular importance to do a seam test before starting regular seaming.
- Visible corners in the top layer shall be rounded to a radius of approximately 30 mm.

Splice Tightness Testing

All splices have to be checked and tested, visually, with a blunt object. Extra attention should be addressed at corners, T-splices, penetrations and the roof perimeter.

If splice strength testing is requested by the building engineer, contact the Technical Department for more information.

5.1 Tape Splicing Technique

Seam Tapes are used for cold seaming of RubberTop Fleece. The same cold splicing technique is used for splicing of details with f.e. Flashing tape, Cover tape,...

5.1.1 Application Prescriptions

Splicing Tape systems can be used for:

- adhered roof systems
- mechanically fastened applications
- ballasted roof systems
- extensive green roofs (with application of an intermediate PE layer of min 0.4 mm)

Tape systems are always applied with Single Ply Primer. The strength of the seam completely depends on the contact between the primer, the EPDM and the tape. It is therefore extremely important to prepare the membrane properly. The Single Ply Primer should only be applied with a scrubber.

By scrubbing the RubberTop Fleece surface, the Single Ply Primer will penetrate in to the irregular surface of the RubberTop Fleece membrane. Once flashed off, the Seam Tape, Cover Tape or Flashing Tape can be installed on the tacky surface. Full curing will take several days.

Limitations

The Tape Seam technique should not be used in temperatures below 5°C, above 30°C or during rain, mist, strong winds or when there is a risk of condensation. SealEco also recommends storing Single Ply Primer at room temperature (20°C) prior to use. At all times Single Ply Primer should have a temperature of min. 15°C when applying.

The EPDM membranes to be joined should be clean, dry, smooth and free from creases or tension. If necessary, the membrane can be cleaned with Cleaning Wash 9700 before joining.

Do not apply the Single Ply Primer in direct sunshine during warm sunny days. Protect the primed surface until Seam Tape, Cover Tape or Flashing is applied.

Scrubbing Pad

It is important to apply Single Ply Primer with a scrubber. The surface needs to be treated to have better grip. However only pass 3 times over the EPDM surface ensure the primer does not dry out while scrubbing. A scrubbing pad can be used for splicing a roll of 30m.

i Note: do not reuse a pad when it has dried out!

Single Ply Primer

Using a drill or mixer, mechanically stir the Single Ply Primer before use. Once stirred, the consistency of the Single Ply Primer changes and appears cloudy or like 'apple-sauce'.

Pour out an amount of primer in a small container so the scrub pad can easily take up the needed amount of primer. Close the lid of the can immediately after.

The poured out primer has to be used within 20 minutes so do not pour out a big amount of primer at once. Do not dilute the primer. If additional primer is needed, again mechanically stir the Single Ply Primer before pouring out.

i Keep out of direct sunshine!

Do not stretch the splice and ensure it is smooth and free from creases. Carefully apply the Single Ply Primer, using a scrubbing pad (not a brush!), onto the entire splice area. The Single Ply Primer shall always be applied 5 mm - 10 mm wider than Seam Tape, Cover Tape or Flashing Tape.

Once applied, leave it uncovered until it has flashed off, so it is touch dry but still tacky. Do not leave the applied primer open for more than 20 minutes at 20 °C and 50% relative humidity.

The splice will obtain its full strength after 48 hours once the surface has completely dried out. In case of precipitation or condensation after applying the primer, the surface should be dried, and a new layer of primer is applied.

Risk For Capillarity

All cut edges and Flashing details need to be treated with Sealant 5590. Apply the sealant with a caulking gun as shown in the next figure. Level out the sealant immediately after with a scoop, do not use soap!

Figure 5

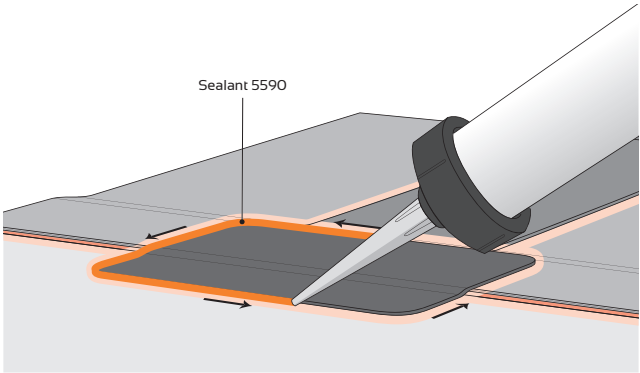

Remark: Irregularities during splicing, f.e. folds, fishmouths, to narrow overlap, should be repaired immediately with a Flashing Tape. See 5.1.6.

5.1.2. Seam Tape Details For Adhered And Loose Laid Applications

Seam Tape is used for connecting two rolls RubberTop Fleece E. Position the RubberTop Fleece E rolls with an overlap of 80 mm. It is important that the tape is visible outside the overlap for at least 5-15 mm. The width of the splice will be minimum 60 mm. Single Ply Primer should always be applied on the entire splicing area.

Figure 6

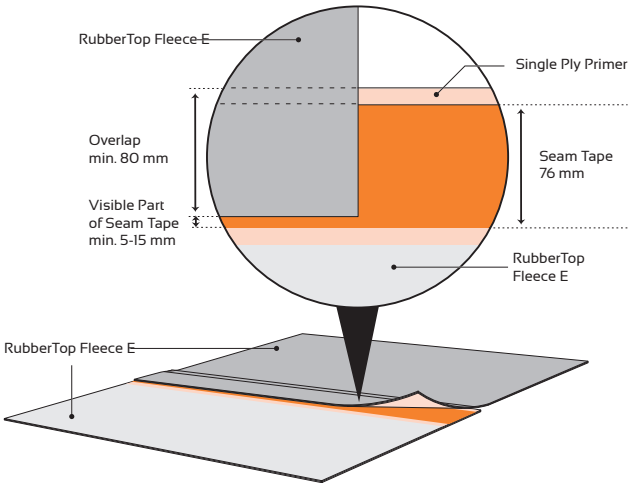

After positioning the roll RubberTop Fleece E, unroll the second with an overlap of minimum 80 mm. When adjoining two rolls, align them in a straight line and place them edge to edge. First start splicing the overlaps and then continue with the cross splices, using a Cover Tape of minimum 152 mm.

Figure 7

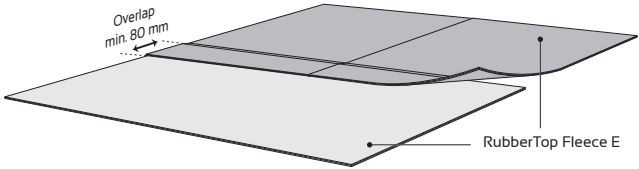

Fold back the overlap (E-edge) and keep it in position.

Apply the Single Ply Primer to both surfaces, according to the instructions.

Wait for Single Ply Primer to flash off. Check by pushing and turning your thumb. When twisting, the thumb should not stick or move.

Figure 8

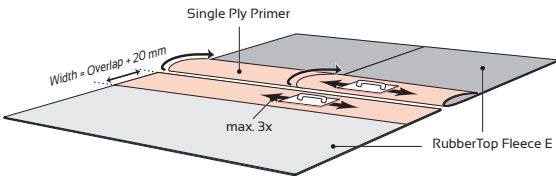

Install the Seam Tape with the release film facing upwards. Align the release foil so that the minimum overlap is guaranteed. Unroll the Seam Tape. Roll with a 40 mm silicone roller without enclosing any air.

Figure 9

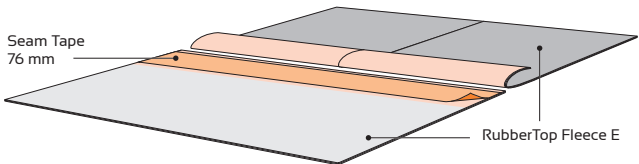

Close the overlap and remove the release foil by pulling it away at a 45° angle as shown in the next figures. Keep the release foil low to the roof surface to reduce air pockets. Press the overlap by hand to prevent wrinkles when rolling the seam. Avoid trapped air between Seam Tape and RubberTop Fleece E overlap.

Figure 10

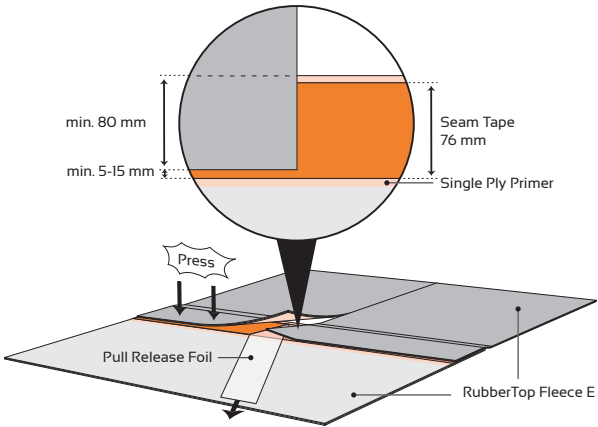
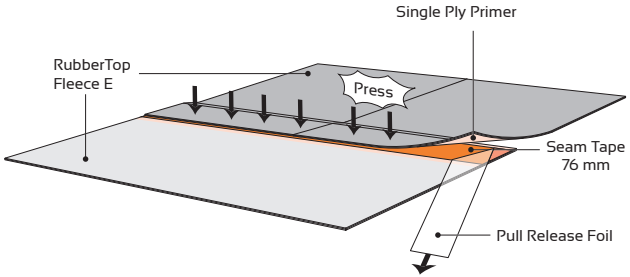
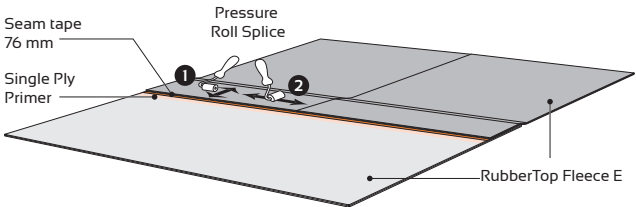

Figure 11



Roll the seam with a silicone pressure roller of 40 mm. First across the seam, preventing trapped air, and afterwards in the length of the seam. At all times 5-15 mm of tape should remain visible. If not, a Flashing Tape has to be spliced on top of this, as a repair.

Figure 12



Position the Cover Tape of min 152 mm with a minimum overlap of 76 mm on each panel, as shown below. Trace line at 10 - 15 mm from the edge of the Cover Tape, roll it back. Apply the Single Ply Primer on the entire splicing area. Once flashed off install the Cover Tape by removing the protection foil and pressing the Cover Tape simultaneously. Roll the seam with a silicone pressure roller as described before.

Figure 13

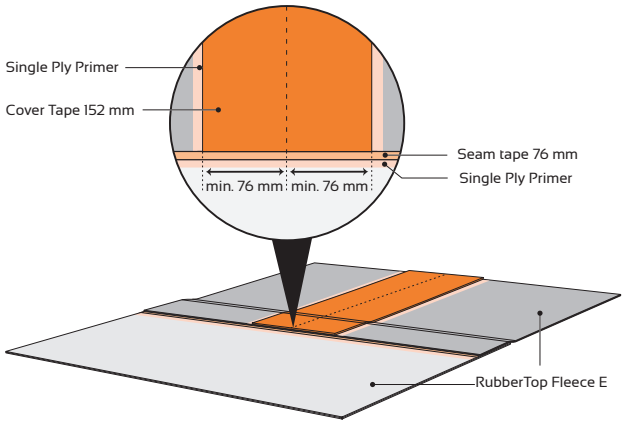

To prevent capillarity, T-splices are secured with a Flashing Tape. Cut a Flashing Tape as explained in figure below. Position the patch, trace line at 10 - 15 mm from the edge of the patch. Apply Single Ply Primer, let it flash off and install the Flashing Tape patch. Roll with a silicone roller as instructed before. T-edges to be rolled also with a brass roller.

Secure the Flashing Tape with Sealant 5590.

Figure 14

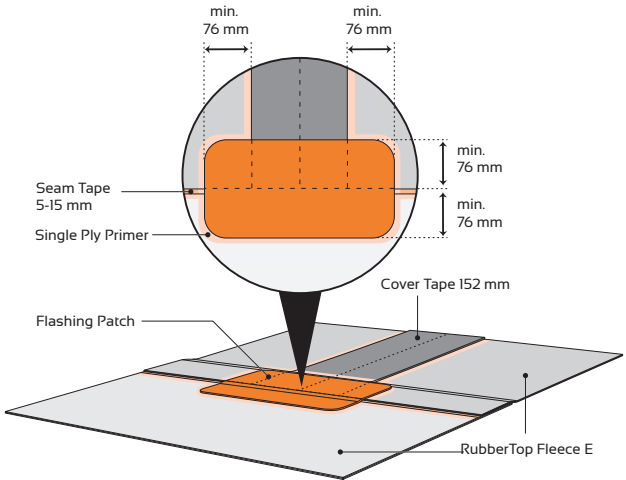

5.1.3. Tape Splicing Details For Mechanically Fixed Applications

For the mechanical fixation of RubberTop Fleece E, a Cover Tape of minimum 229 mm will be used for making seams. The RubberTop Fleece membrane is unrolled with an overlap of minimum 60 mm (70 mm in case of round washers of 50 mm). Fasten both membranes in the overlap.

Figure 15

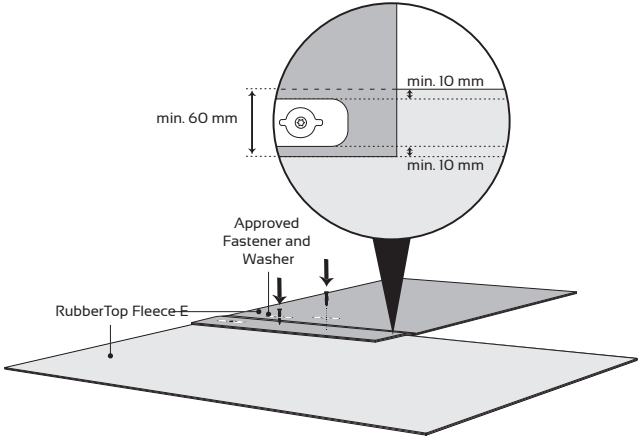

When adjoining two rolls, align them in a straight line and fasten them in the overlap as shown in the figure below. Put markings at a distance of min. 90 mm at both sides of the washers.

Figure 16

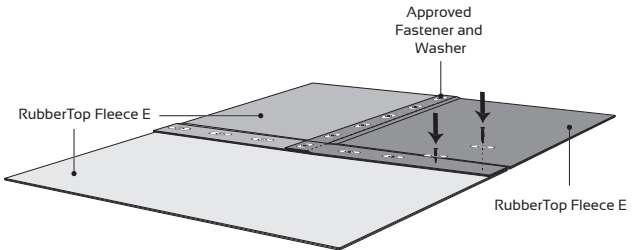

Apply the Single Ply Primer. Wait until Single Ply Primer to flash off. Check by pushing and turning your thumb. When twisting, the thumb should not stick or move. Position the Cover Tape on the cross seam, as shown in the next figure. Remove the protection foil and press the Cover Tape simultaneously. Roll the seam with a silicone pressure roller, first across the seam, preventing air blisters, and afterwards in the length of the seam.

Figure 17

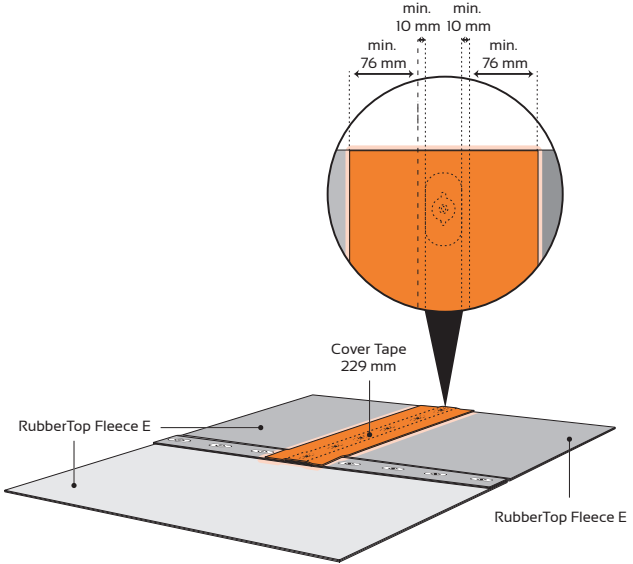

Put markings at a distance of min. 90 mm at both sides of the washers of the longitudinal seam.

Single Ply Primer shall always be applied on the entire splicing area. Apply the Single Ply Primer. Wait until Single Ply Primer to flash off. Check by pushing and turning your thumb. When twisting, the thumb should not stick or move. Position the Cover Tape on the longitudinal splice. Roll the Cover Tape with a silicone pressure roller of 40 mm. First across the seam, preventing trapped air, and afterwards in the length of the seam.

Figure 18

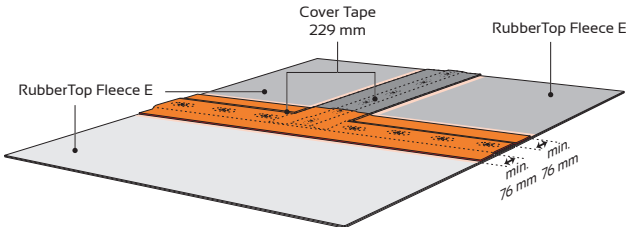

To prevent capillarity, T-splices are secured with a Flashing Tape. Cut a Flashing Tape as explained in the next figure. Position the patch, trace a line at 10 - 15 mm from the edge of the patch. Apply Single Ply Primer, let it flash off and install the Flashing Tape patch.

Roll with a silicone roller as instructed before. T-edges to be rolled also with a brass roller.

Secure the Flashing Tape with Sealant 5590.

Figure 19

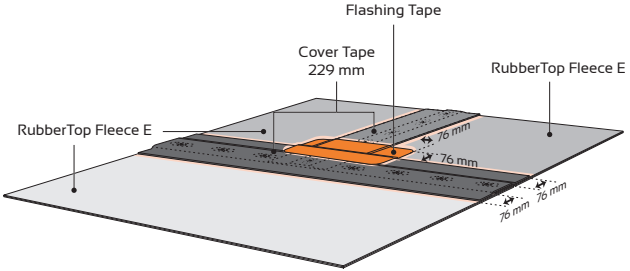

5.1.4. Tape Splicing – End Of Seam Tape

When an additional length of Seam Tape is required, use the following procedure:

Apply Single Ply Primer onto both membranes over the entire length of the seam. Let it flash off. Position the Seam Tape but don't remove the protection foil yet.

Figure 20

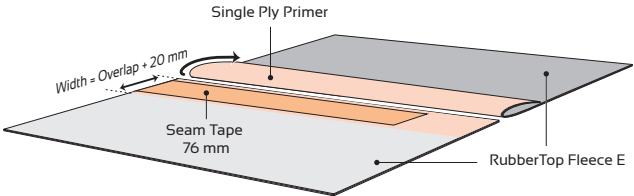

The adjoining Seam Tape is unrolled with an overlap of at least 25 mm. The overlap should not be primed! Tear away only the release foil, where the tapes are overlapping.

Figure 21

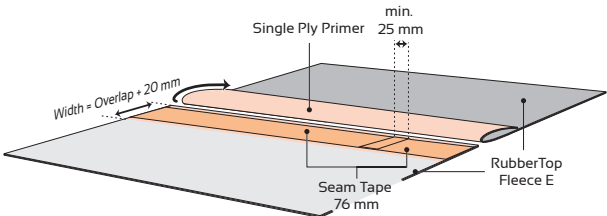

Close the overlap. Now remove the protection foil, mate the overlap with your hands and roll with a silicone roller. First across the seam and afterwards in the length of the seam. At all times 5-15 mm of tape shall be visible.

Figure 22

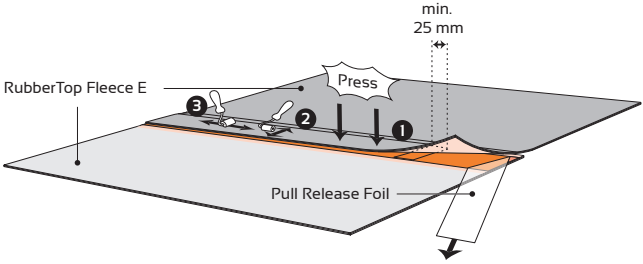

Cut a piece of Flashing Tape as shown on the figure below. Apply Single Ply Primer on the entire splicing area and install the Flashing Tape. Roll the surface with a 40 mm wide silicone roller. All T-splices should be pressed with a brass roller. Secure the Flashing Tape with Sealant 5590.

Figure 23

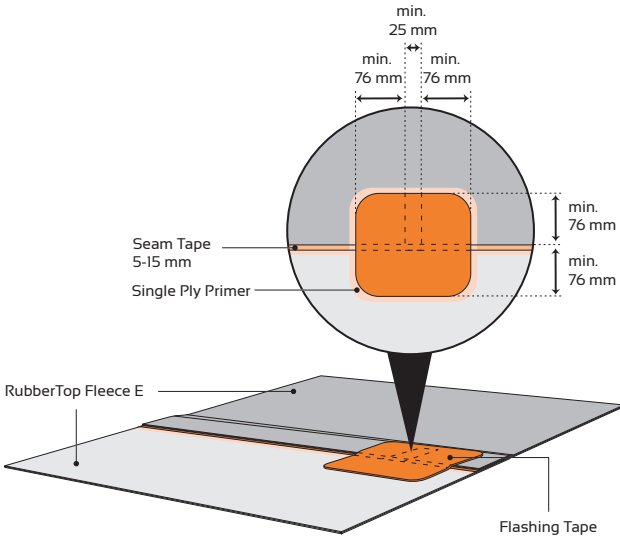

5.1.5. Tape Splicing – End Of Cover Tape

When an additional length of Cover Tape is required, the adjoining roll should overlap at least 25 mm, as shown in the next figure. Apply the first Cover Tape strip. Apply Single Ply Primer for the adjoining Cover Tape but also on the overlap.

Figure 24

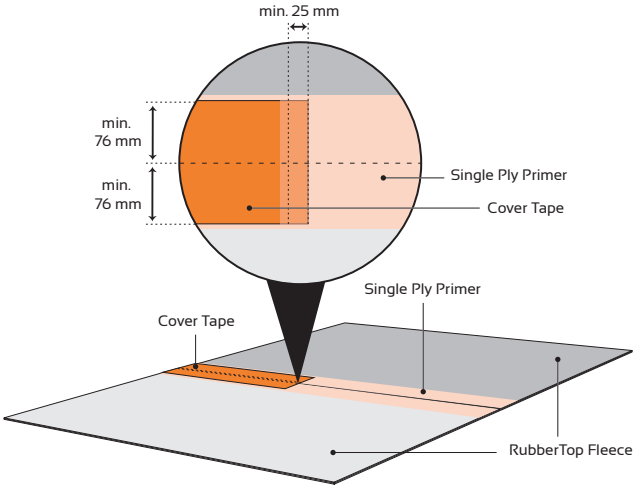

Unroll the adjoining Cover Tape with a minimum overlap of 25 mm.

Figure 25

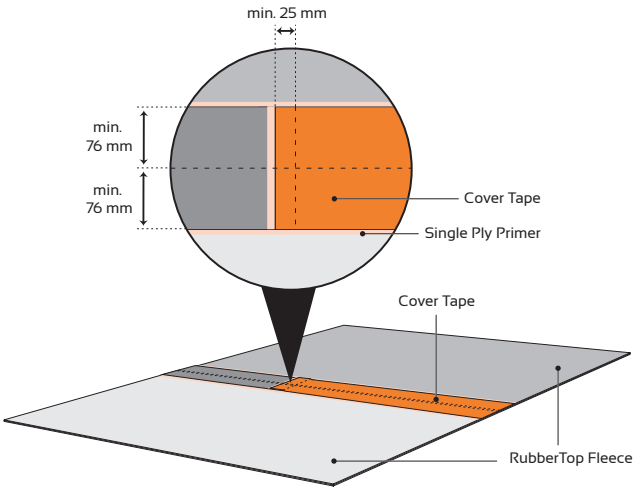

Cut a piece of Flashing Tape as shown in the next figure. Apply Single Ply Primer on the splice area and install the Flashing Tape. Roll with a 40 mm wide silicone roller. Additionally roll all T-splices with a brass roller. Secure the patch with Sealant 5590.

Figure 26

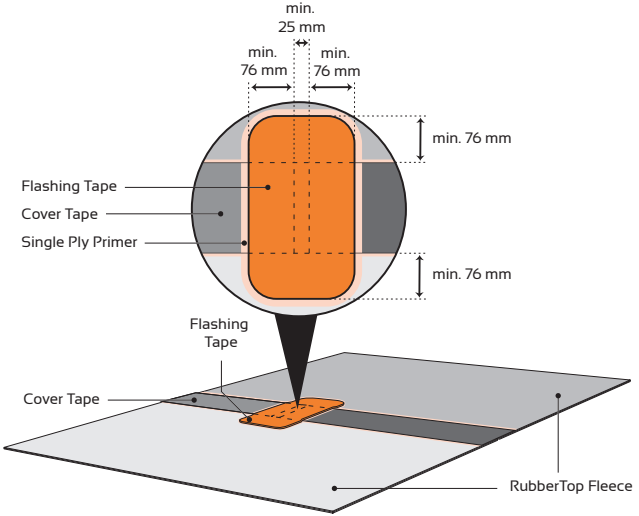

5.1.6. Additional Flashing Tape Corner Patching

RubberTop Fleece E is spliced with an overlap of min 80 mm. Do not stretch the membrane during splicing. Flashing Tape should be applied according to the figure below. Follow all splicing instructions. Seal with Sealant 5590.

Figure 27

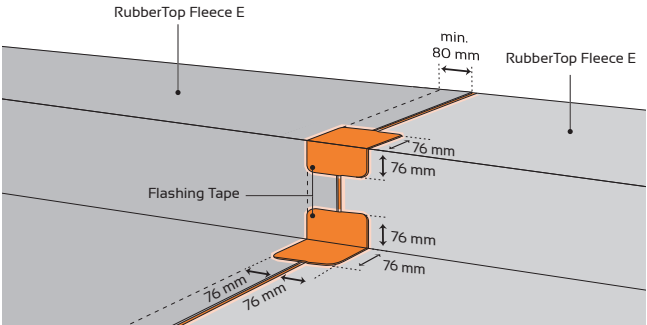

5.1.7. Tape Splicing: Repairs

Start by locating the damage and try to find out the reason for it: installation failure, mechanical damage etc. When the reason is established, it is easier to prevent similar damage.

Measure the size of the damage and cut a Flashing Tape piece to the dimensions required.

If the damage area is bigger it can be repaired by applying a new RubberTop Fleece membrane. All seams can be done with Cover Tape following the general instructions for Tape Splicing.

The surface of the existing membrane must be ground and properly cleaned with Cleaning Wash 9700 and be left to dry. Apply Sealant 5590 onto all details, cut edges and T-splices.

Figure 28

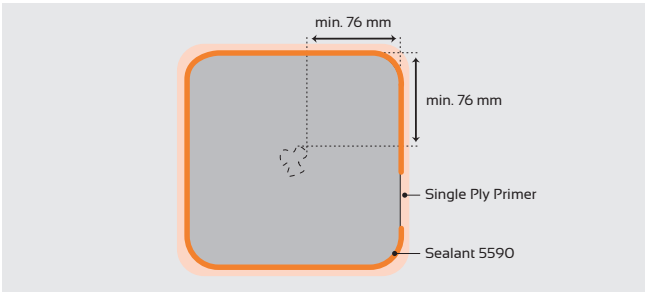

6 Horizontal Installation Of RubberTop Fleece

6.1 RubberTop Fleece Adhered

Substrate

RubberTop Fleece can be adhered on all common substrates such as: concrete, wood, bitumen, and insulation. Make sure that the adhesive is compatible with the insulation chosen. Check the technical data sheet of the insulation. Please contact our Technical Department for adhesion onto naked EPS and MW insulation. We recommend that all types of insulation are coated with a mineral, polyester, or bituminous layer. SealEco advises not to use aluminium faced insulations except when full scaled windloadtests and aging tests have been made.

The substrates must be clean, dry (unless differently specified) and free of grease and oils. At roof slopes over 10° (>1:6) the membrane must be mechanically fastened at the upper side, with approved fasteners spaced 200 mm, to avoid slippage.

When adhering the RubberTop Fleece, always start at the lowest part of the roof, either in a valley or at a roof edge. From this position the lay-out of the membrane is done across the slope direction with a minimum overlap depending on the splicing technique. The RubberTop Fleece rolls shall be positioned so that they can be unrolled into their final position without adjustments. Two parallel lines are printed on the RubberTop Fleece membrane for fast positioning.

Climate Conditions

The minimum temperature for adhering is 5°C. If temperatures are between +5°C and 15°C we recommend storing adhesives inside at 20°C. Preheating up to 50°C could be an option. (Contact our Technical Department for more information).

It is not allowed installing RubberTop Fleece membranes during any precipitation.

Wind Load

The maximum allowed wind load will depend on the type of adhesive and the complete build-up of the roof.

Wind load calculations have to be provided by the building engineer. In case of renovation a test adhesion is needed. Add this result in the "as built plan". For more information on the wind load for different roof systems please contact our Technical Department.

It is the responsibility of the roofer to choose the correct roof build-up. Depending on the wind load, and the roof build-up, a method for perimeter fixing and fixing around roof penetrations will be determined. More instructions are available in chapter 7 'Base Tie-In'.

- ❗ Note: when the allowed wind load for an adhered system is less than the actual wind load, a combination with a ballast layer can be an option. Please don't forget to check the load with the building engineer.

Types Of Adhesives

RubberTop Fleece can be adhered with different adhesives (availability depending on country):

- Adhesion with Polyurethane Adhesive PUR 3200
- Adhesion with Ecobond
- Adhesion with Spraybond E245
- Adhesion with Spray Contact Adhesive P125

6.1.1. RubberTop Fleece Adhered With Polyurethane Adhesive PUR 3200

All general instructions have to be followed. Read the MSDS before use.

Directions For Use

Adhesive PUR 3200 is applied in beads by punching holes with a diameter of 6 mm spaced 50 mm in the can and using the can to spread the adhesive. Minimum processing temperature is +5°C. If temperatures are between +5°C and 15°C it is recommended to pre-heat the adhesive to a maximum of 50°C before use. Splicing areas on the membrane should be kept free from adhesive. Clean the splice with Cleaning Wash 9700 immediately if PUR 3200 is spilled in that area.

The coverage should be approximate 350 g/m². Do not spread adhesive over larger roof areas than you can cover in approx. 20 minutes (at 20°C).

Roll out the membrane into the adhesive. Immediately after unrolling the RubberTop Fleece use a broom to brush the membrane so it is pressed down into the adhesive and lays smooth on the roof. Repeat this after 30 minutes without stretching the membrane.

The curing time of the adhesive varies between 1 hour and 2 days depending on temperature and humidity.

- ❗ Remark: an excessive amount of adhesive will result in blisters.

Admissible Wind Load RubberTop Fleece Adhered With PUR 3200

Adhesive

Please contact our Technical Department for information concerning wind load values.

Suitable Substrates

PUR 3200 provides good adhesion on concrete, wood and old bitumen. Adhesion on bitumen with low melting point, with slates, sand or chalk is not allowed.

Adhesion On Insulation

Before adhering RubberTop Fleece on insulation, the installer should consult the technical data sheet of the insulation and check if adhesion is allowed. Adhesion on EPS is not allowed.

- ❗ Note: At roof slopes over 10° (>1:6) the membrane must be fastened mechanically at the upper side, with approved fasteners spaced 200 mm, to avoid sliding off.

6.1.2. Adhered With Ecobond V / Ecobond H

All general instructions have to be followed when using Ecobond. Read the MSDS before use.

Directions For Use

Ecobond is applied in beads by means of an adapted gun. The adhesive is applied in beads of approximate 10 x 5 mm with a distance of 120 mm. Minimum processing temperature is +5°C. If temperatures are between +5°C and 15°C it is recommended to pre-heat the adhesive to a maximum of 30°C before use. Splicing areas on the membrane should be kept free from adhesive. Clean the splice with Cleaning Wash 9700 immediately if Ecobond is spilled in that area.

Once the adhesive is applied, the membrane should be unrolled within 10 minutes and pressed with a hard brush or roller, obtaining an adhesion width of approximate 25 mm/bead. It is important that, when adhering in beads, a distance of 120 mm between them is kept. Curing will take between 1 to 15 days depending on the substrate, temperature and the humidity. Please take precautions if heavy wind loads are expected within 72 hours after installation. For partially adhered application coverage is between 340 and 650 g/m². By increasing the temperature, the viscosity drops and application speed increases. In case of dry substrates and low humidity, substrates or covering material should be slightly moistened.

Admissible Wind Load RubberTop Fleece Adhered With Ecobond

Adhesive

Please contact our Technical Department for information concerning wind load values.

Suitable Substrates

Ecobond provides good adhesion on concrete, wood, old bitumen and metal. Adhesion on bitumen with low melting point, with slates, sand or chalk is not allowed.

Adhesion On Insulation

Before adhering RubberTop Fleece on an insulation, the installer should consult the technical data sheet of the insulation and check if adhesion is allowed. In case of adhesion on naked EPS, please contact our Technical Department.

- i** Note: At roof slopes over 10° (>1:6) the membrane must be fastened mechanically at the upper side, with approved fasteners spaced 200 mm, to avoid sliding off.

6.1.3. Adhered With Spray Contact Adhesive P125

All general instructions have to be followed when using P125. Read the MSDS before use.

Directions For Use

P125 is a sprayable contact adhesive for bonding RubberTop Fleece to different substrates. The adhesive is applied with adapted spray equipment and air pressure is needed. Contact Adhesive P125 will only be used for fully adhered applications.

Minimum processing temperature is +5°C. If temperatures are between +5°C and 15°C it is recommended to pre-heat the adhesive to a maximum of 30°C before use. Splicing areas on the membrane should be kept free from adhesive. Clean the splice with Cleaning Wash 9700 immediately if P125 is sprayed onto the membrane.

When spraying keep a distance of 10 - 25 cm to the substrate.

Apply P125 evenly to coat both surfaces, substrate and backside of the RubberTop Fleece membrane. Let the P125 flash off. Unroll the membrane onto the substrate without tension, sweep away all enclosed air with a brush, and press firmly with a roller (drying time is about 2 - 5 minutes.)

The coverage should be approx. 450 g/m². Maximum open time is 30 minutes (depending on atmospheric conditions). Excessive adhesive, too short or too long drying time, humid substrates, dust, etc. will result in blisters.

To ensure proper application we recommend a training course before

using this adhesive. During this training, roofers will also be informed about safe use and maintenance of spray equipment.

The curing time of the adhesive varies between 1 hour and 2 days depending on temperature and humidity.

Admissible Wind Load RubberTop Fleece Adhered With P125 Adhesive

Please contact our Technical Department for information concerning wind load values.

Suitable Substrates

Spray Contact Adhesive P125 is especially designed for bonding an EPDM membrane to building materials, such as: insulation, wood, concrete and steel. Surfaces must be clean, dry and free of dirt, dust, oil, paint and grease. Not to be used on bitumen. Concrete, cellular concrete or other porous substrate should be sprayed twice. First time left to dry as a primer before applying the adhesion layer. The coverage as a primer should be approx. 150 g/m².

Adhesion On Insulation

Before adhering RubberTop Fleece on an insulation board, the installer should consult the technical data sheet of the insulation and check if adhering is allowed. Adhering on naked EPS, and mineral wool is not allowed.

- i** Note: At roof slopes over 10° (>1:6) the membrane must be fastened mechanically at the upper side, with approved fasteners spaced 200 mm, to avoid sliding off.
- i** Note: P125 is extremely flammable. Read the material safety data sheet before transport, storage or use.

6.1.4. Adhered With Spraybond E245

All general instructions have to be followed when using Spraybond E245. Read the MSDS before use.

Directions For Use

E245 is a sprayable contact adhesive for bonding RubberTop Fleece to different substrates. The adhesive is applied with adapted spray equipment. E245 is delivered in pressurised canister, so compressed air is not needed. Spraybond E245 should only be used in fully adhered applications. Minimum processing temperature is +5°C. If temperatures are between +5°C and 15°C it is recommended to pre-heat the adhesive to a maximum of 30°C before use. Splicing areas on the membrane shall be kept free from adhesive. Clean the splice

area with Cleaning Wash 9700 immediately if E245 is sprayed onto the membrane.

When spraying, keep a distance of 10 - 25 cm to the substrate.

Apply E245 evenly to coat both bonding surfaces. Let the E245 flash off until it is hand dry. Join the parts to be bonded together, without tension and press firmly with a roller (drying time is about 2 - 5 minutes.) The coverage should be 450 g/m². Maximum open time is 30 minutes (depending on atmospheric conditions).

Excessive adhesive, too short or too long drying time, humid substrates, dust, etc. will result in blisters. To ensure proper application we recommend a training course before using this adhesive. During this training, roofers will also be informed about safe use and maintenance of spray equipment.

The curing time of the adhesive varies between 1 hour and 2 days depending on temperature and humidity.

Admissible Wind Load RubberTop Fleece Adhered With E245 Adhesive

Please contact our Technical Department for information concerning wind load values.

Suitable Substrates

Spraybond E245 is especially designed for bonding an EPDM membrane to building materials, such as: insulation, wood, concrete and steel. Surfaces must be clean, dry and free of dirt, dust, oil, paint and grease. Not to be used on bitumen. Concrete, cellular concrete or other porous substrate should be sprayed twice. First time left to dry as a primer before applying the adhesion layer. The coverage as a primer shall be approx. 150 g/m².

Adhesion On Insulation

Before adhering RubberTop Fleece onto an insulation board, the installer should consult the technical data sheet of the insulation and check if adhering is allowed.

- i** Note: At roof slopes over 10° (>1:6) the membrane must be fastened mechanically at the upper side, with approved fasteners spaced 200 mm, to avoid sliding off.
- i** Note: Spraybond E245 is extremely flammable. Read the material safety data sheet before transport, storage and use.

6.2 RubberTop Fleece Mechanically Fastened

Substrate

All general instructions have to be followed. Mechanical fastening of RubberTop Fleece is possible in different substrates: corrugated metal, wood, concrete and cellular concrete. Use only the prescribed stress plates and fasteners, because this will have a huge impact on the wind load. Ask our Technical Department for more detailed information.

Make sure that the mechanical attachments are properly fastened in the substrate and that the washer is close and tight to the RubberTop Fleece membrane. In case of high energy saving demands, very thick insulation layers or softer insulation types, telescopic tubes should be used.

Apart from our instructions, also the instructions of the manufacturer of fasteners have to be followed. It is very important not to pre-tension the fastener while fixing the RubberTop Fleece. Do not tighten the screws too much because this will cause wrinkles in the RubberTop Fleece membrane and complicate splicing.

In case of refurbishment, it is compulsory to examine the actual state of the roof and perform pull-out tests to determine the calculation value of the fastener for making a proper wind load calculation. Add the test results to the "as built plan".

Climate Conditions

Mechanical fixation of RubberTop Fleece is not limited by temperature, however splicing is. We recommend following temperatures for splicing:

- Cold splicing techniques: +5°C – +30°C
- ❗ More detailed instructions are available in the chapter 5: 'Splicing'.
- ❗ Installation of RubberTop Fleece is not allowed during any precipitation.

Wind Load

The number of fixations, the size and form of the washers depend on the wind load acting on the roof. Therefore a detailed fastening plan for the RubberTop Fleece membrane, based on an unique wind uplift calculation for the project, is needed. Wind load calculations have to be provided by the building engineer.

If the needed rows for fastening are less distanced than the standard width, an additional row of fasteners can be foreseen in the middle of the membrane and be covered with Cover Tape. At all times a mechanically fixed base tie-in should be applied.

Types Of Fasteners

SealEco has performed several wind load tests for mechanically fixed RubberTop Fleece membranes in different substrates and with different fasteners. We only allow the use of approved fasteners and pressure plates. Please contact our Technical Department for more information.

6.3 RubberTop Fleece Ballasted

All general instructions have to be followed.

It is very important that the structure can withstand the weight of the ballast. It is important to check where the ballast can be placed before spreading out.

Ballast can carry out several functions:

- fully ballasted roof to withstand wind forces on the roof, in full
- additional weight to a mechanical or adhered roof to meet the needed wind load calculations
- fire regulations
- walking pads for frequent passage on roofs
- terraces
- green roofs

At all times a non-woven protection layer of min. 300 g/m² will be installed between the RubberTop Fleece membrane and the ballast layer. In case of an increased risk for damage, (e.g. large tiles, use of heavy equipment) during or after handling the ballast layer, a more performant protection layer has to be considered, to prevent any mechanical damage.

Climate Conditions

When RubberTop Fleece is loose laid with only a ballast layer, the installation is not limited by temperature, however splicing is. We recommend following temperatures for splicing:

- Cold splicing techniques: +5°C – +30°C
- ❗ More detailed instructions are available in the chapter 5: 'Splicing'.
- ❗ Installation of RubberTop Fleece is not allowed during any precipitation.

Wind Load

The weight of the ballast must be adapted for each building and be based upon local conditions and requirements. Examples that influence the needed load from ballast are: wind zone, terrain, height and shape of building, height of parapets, wind- and airtightness of the building, etc. We recommend at all times a ballast weight of minimum 80 kg/m². If less ballast is applied, additional fixing of the membrane is needed. The influence from wind load is always

greater in the corners and at perimeters of the roof than in the field. Therefore gravel ballast e.g. shall be applied with a thicker layer in corner and perimeter zone than in the field.

A general guide to designing gravel thickness can be:

- Thickness x 1 in Field Zone
- Thickness x 2 in Perimeter Zone
- Thickness x 3 in Corner Zone

Apart from the weight of the ballast layer, also the weight of each separate ballast piece has to be considered. The choice for the size of gravel, the thickness and size of pavers are part of the wind load calculation, to be provided by the building engineer. At all times the ballast shall be applied immediately after installation of the RubberTop Fleece.

Types Of Ballast

Examples of suitable ballast are: gravel, pavers, concrete or timber. A combination of them is also possible. It is important that the weight of the ballast is spread out equally over the surface. Large plants/trees on the roof, solar panels, technical installations, etc. are not to be counted as a ballast load as such.

6.3.1. Ballasted With Gravel

When ballasting RubberTop Fleece, a protection layer type non-woven polyester of min. 300 g/m² will be unrolled between the gravel and the EPDM. The non-woven polyester will be unrolled with an overlap of minimum 300 mm. Only washed and uncrushed gravel can be used as ballast layer.

The maximum slope of a roof with gravel is 5%.

When gravel is used for fire protection, a thickness of minimum 50 mm is needed. Check local demands for more details.

6.3.2. Ballasted With Tiles And Pavers

There are different ways of installing pavers and tiles on a waterproofing. Check that the weight of the tiles can withstand the wind load. Tiles and pavers can be laid in sand or on paving supports. A protection layer is needed at all times. In both cases it is very important that the upstand is well protected so that tiles can't perforate the RubberTop membrane. When using tiles on terrace supports, the compression strength of the insulation must be sufficient, therefore a thick protection layer between the RubberTop Fleece and the supports is required.

- ❗ When tiles are used for fire protection, a thickness of min 40 mm is needed. Check local demands for more details.

6.3.3. Ballasted with timber

Ensure the load is correct for installation on a timber roof, considering that the density of the timber itself might be insufficient to give proper resistance to the wind load. Install a protection layer of at least 300 g/m² between EPDM and wood.

- i** Note: If the timber deck is treated with wood oil, or similar there must be a protection layer such as polyethylene foil on top of the RubberTop Fleece to prevent chemical damage.
- i** SealEco recommends fastening the membrane at all times, when the roof is ballasted with a wooden deck roof.

6.4 RubberTop Fleece Green Roof

All general instructions have to be followed.

It is very important that the structure, the insulation and all other layers can withstand the weight of the green roof. This means the system, vegetation, insulation, water, etc.

Types Of Green Roof

Seams of RubberTop Fleece will be spliced with a cold splicing technique. Note that there are two different green roof systems:

1. Intensive green roof:

The weight of intensive green roofs starts at 100 kg/m², and the type and amount of layers will depend on the vegetation. This type of green roof can be chosen for slopes up to 30°. At all times the membrane and its splicing method should pass the test for root penetration according to EN 13984 or FLL. Even when passing these tests, supplementary protection is needed to prevent damage during installation and because of aggressive roots.

RubberTop Fleece can not be used in combination with intensive green roofs.

- i** Seek advice at your green roof supplier or our Technical Department.

2. Extensive green roof:

The weight of an extensive green roof varies from 20 to 100 kg/m². This mainly depends on the water content. Extensive green roofs can be installed on roofs with slopes up to 35°.

RubberTop Fleece can be used for extensive green roofs when a PE layer of at least 0.4 mm should be installed on top of the RubberTop Fleece membrane. The PE layers shall be unrolled with an overlap of at least 1 m. Ensure all national guidelines are followed.

Wind Load And Adhesion

We recommend at all times adhering or mechanically fastening RubberTop Fleece in combination with green roofs. This is also compulsory in several countries because of national regulations.

- i** Note: Don't forget that the weight of an extensive green roof, in dry conditions, might not be sufficient to take over the function of a proper ballast layer!
- i** If slopes are above 10°, adhesion or mechanical fastening is needed.

Thickness

Depending on national regulations the minimum thickness for RubberTop Fleece can vary. SealEco advises a minimal thickness of 1.1 mm for fleecebacked EPDM membranes and a minimal thickness of 1.5 mm for standard EPDM membranes to minimize the risk for mechanical damage during installation of the green roof system.

- i** Note: Please check the roof together with the architect, building engineer or building owner before installing the green roof layers. If possible make a smoke or water test. You don't want to be held responsible for damage made by the green roof installer, etc. Rhizomes and aggressive roots might penetrate the membrane and its splices. Contact our Technical Department for more information.

7 Base Tie-In

During the handling and production of RubberTop Fleece EPDM membranes, stresses are introduced. This is inherent for all elastomeric membranes. Apart from these stresses also the thermal influence and the structural movement of buildings necessitate fastening of the RubberTop Fleece membrane alongside all roof edges, walls, drains, pipes and skylights.

All places where the substrate makes a change in angle greater than 10° should be considered as an upstand and treated accordingly.

Base Tie-In Design

The design of the base tie-in depends on the actual stresses. When the securement is insufficient, the RubberTop Fleece will pull away. We recommend at all times using a mechanical fastened base tie-in. In some cases adhered base tie-in solutions are allowed. It remains however the responsibility of the roofer to choose the correct base tie-in method.

Mandatory Mechanical Base Tie-In With RubberTop Fleece

In following cases a mechanical fastening is required:

- Mechanical fastened RubberTop Fleece roofing system.
- On all metal and wooden construction that are air open.
- When using a separate upstand strip.
- Wind load > 1500 Pa.
- When using a loose laid insulation or underlayer.
- Roofs with a slope of 10% or more.
- Insulation with high risk of delamination, e.g. uncoated mineral wool, EPS, etc.
- Roofs > 50 m².
- Parapets with height > 500 mm.
- Installation directly on screed, EPS mortars.
- Installation on bitumen coated with slates or sand.
- Installation on substrates not compatible with adhesives.

Allowed Adhered Base Tie-In RubberTop Fleece

In some cases a perimeter attachment with adhesives can be allowed, however only under these conditions:

- The application is not part of the list of mandatory mechanical fixed base tie-in mentioned above.
- Follow the special instruction for splicing in roof edges, and along parapets.
- Parapets are fully adhered and fixed mechanically at the top.

i Note: Adhered base tie-in on coated insulations are always a risk because of the limited adhesion of the facer to the insulation. Delamination between facer and insulation itself is outside SealEco's control and is the responsibility of its manufacturer. It is very important to check the TDS of the insulation and compatibility with the applied adhesives.

7.1 Mechanical Fastened Base Tie-In RubberTop Fleece

Follow the general instructions for fastening, adhering or ballasting RubberTop Fleece. Use the correct fasteners and pressure plates. Pull out value of the fasteners should be minimum 400 N.

SealEco prefers perimeter fixing in the horizontal roof surface, but allows vertical base tie-in when roof build-up is too thick, or when the horizontal roof surface is not suitable for fastening. The use of a termination bar instead of pressure plates is also allowed.

All washers or batten bars should be installed as close as possible to the angle changes, following these directions:

- Maximum distance to change of angle is 20 mm.
- Minimum distance to the edge of the membrane is 10 mm.
- No fastener closer than 200 mm to an inner or outer corner.
- The distance in between the fasteners should be max. 200 mm.

For the upstand a RubberTop or a RubberTop Fleece strip can be used. These have to be fully adhered to the substrate and spliced to the membrane.

Figure 29

Base Tie-in with washers or termination bar in the roof surface.

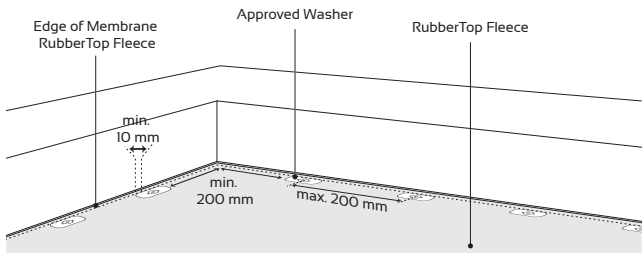
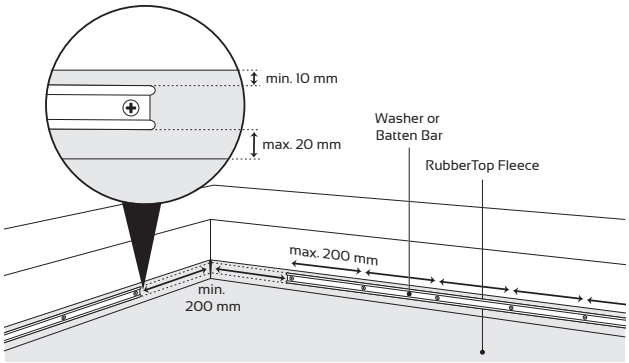

Figure 30
Base Tie-in with washers or termination bar in the upstand.



7.2 Adhered Base Tie-In RubberTop Fleece

Follow the general instructions for adhered and ballasted roofs. Check that all parameters for adhered perimeter fixing are fulfilled. We make a distinction between adhered and ballasted roofs.

7.2.1. RubberTop Fleece Adhered Application

RubberTop Fleece membrane is adhered with approved adhesives on the horizontal surface. When RubberTop Fleece is partially adhered it is necessary to fully adhere 1 meter around the perimeter and upstands. When the horizontal roof part is fully adhered, no additional adhesion is required. Adhesion of the upstand is explained in chapter 8.

Figure 31

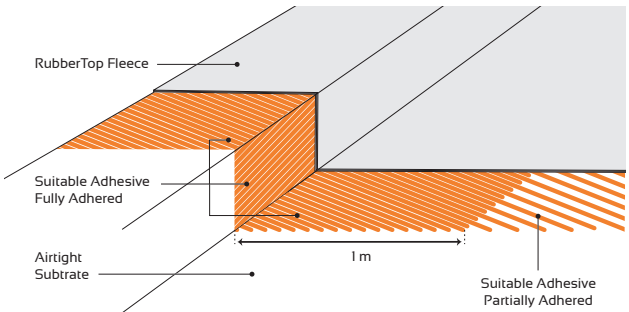

7.2.2. Base Tie-In RubberTop Fleece Ballasted And Green Roofs

Follow the instructions for installing RubberTop Fleece for ballasted and green roof applications. When it is allowed to install RubberTop Fleece, with ballast or a green roof system without any adhesive, and when a mechanical base tie-in is not mandatory, fully adhered base tie-in is allowed with Contact Adhesive 5000, Spraybond E245, Spray Contact Adhesive P125 and Ecobond. Check the compatibility before use.

i The width of the adhered base tie-in is minimum 500 mm.

Figure 32

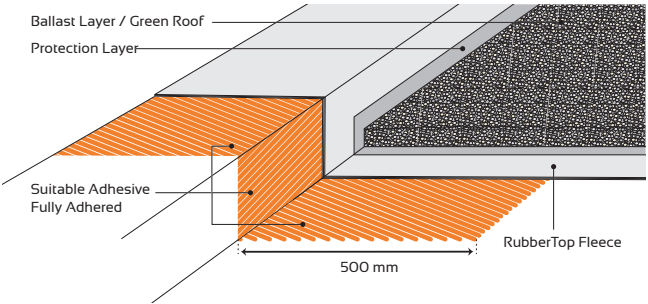

8 Upstands

All places where the substrate makes a change in angle greater than 10° shall be considered as an upstand and treated accordingly. SealEco advises at all times to break the RubberTop Fleece membrane and make a mechanical anchoring. This is done in addition to the membrane securement in the field area and should be done at perimeters and walls but also for penetrations in the field. Upstands can be covered with different types of SealEco EPDM membranes: RubberTop Fleece - RubberTop strip. The upstand shall at all times be fully adhered with an appropriate adhesive. Wind open upstands, skylights, details, etc. have to be sealed properly before applying the EPDM membrane.

8.1 Upstand With Cold Splicing Technique

8.1.1. Base Tie-In In Upstand

The horizontal surface is installed according to the instructions. A mechanical base tie-in is required in the upstand (chapter 7). The RubberTop Fleece E / RubberTop is fully adhered on the upstand with Contact Adhesive 5000, Spraybond E245 or Spray Contact Adhesive P125. Firmly roll the membrane with a pressure roller. Splicing is done according to all cold splicing instructions (see chapter 5).

Figure 33

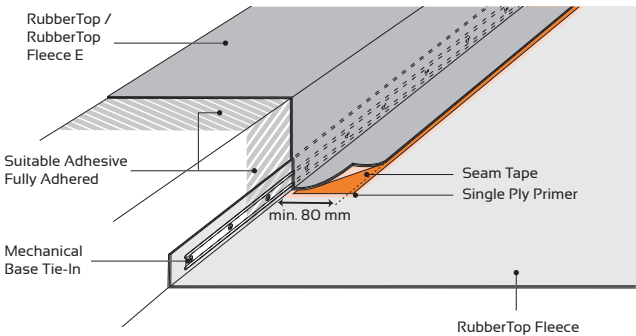

8.1.2. Base Tie-In In Horizontal Roof Surface

The horizontal surface is installed according to the instructions. A mechanical base tie-in is required in the horizontal roof surface (chapter 7).

Adhere the membrane with Contact Adhesive 5000, Spraybond E245 or Spray Contact Adhesive P125. Firmly roll the upstand strip with a pressure roller. Splicing is done according to all cold splicing instructions (see chapter 5).

Figure 34

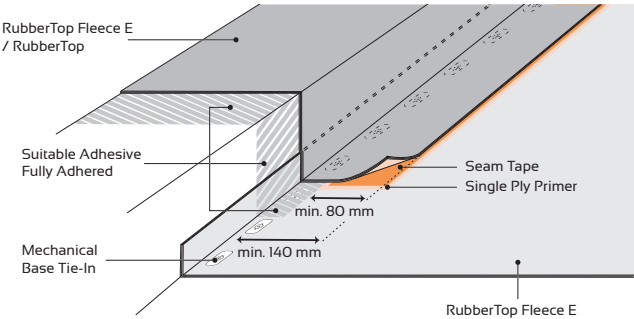

8.2 Upstand With Adhered Base Tie-In

In some cases it is allowed to install RubberTop Fleece with an adhered base tie-in. When overlap splices pass the roof angle, an additional safety patch has to be applied (see chapter 5). It is very important that there is no tension at all in the corner when splicing the membrane. Please consult chapter 7 for more information about base tie-in. On the vertical surface, RubberTop Fleece is always fully adhered with Contact Adhesive 5000, E245 or P125. Once splicing is finished, apply an additional corner patch for securing the RubberTop Fleece splicing.

Figure 35

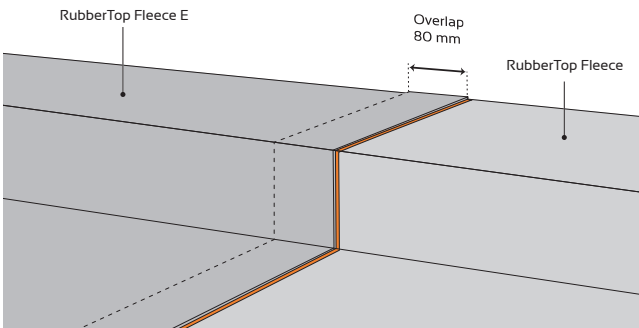

9 Internal Corners

General Instructions

The design of corners with a RubberTop Fleece depends on several parameters:

- Fixing method
- Upstand and base tie-in design

Important rules to be followed at all times:

- The membrane shall be 100% clean. If not, use Cleaning Wash 9700.
- Follow all splicing instructions.
- All layers around the corner are properly fixed and adhered.
- Tension in the underlying layers is not allowed at all.

i Note: At all times RubberTop Fleece needs to be fixed mechanically at all roof edges. It is very important that the fleece backing is not in direct contact with water, because of a high risk for capillarity. All edges of RubberTop Fleece should be protected at all times!

i Note: In this chapter drawings are not provided with any base tie-in design. All instructions according to base tie-in have to be followed (chapter 7).

9.1 Internal Corners With Mechanically Fastened Base Tie-In

A separate EPDM strip to flash the upstands is used when a base tie-in is mechanically fastened. Depending on the type of the EPDM strip, different techniques to flash the corner will be used.

9.1.1 Flashing Tape Splicing Technique

RubberTop Fleece E Or RubberTop Upstand

1. Cut a strip RubberTop Fleece E or RubberTop EPDM as shown in the next figure. Adhere fully to the substrate. Keep the splicing areas free of adhesive and clean with Cleaning Wash 9700 when needed. The overlap for splicing with the roof membrane is at least 80 mm. The total overlap depends on the base tie-in design. Make the horizontal seam. Continue in the same way with the adjoining EPDM strip, but cut the overlap in 45° as shown in figure 37.

Figure 36

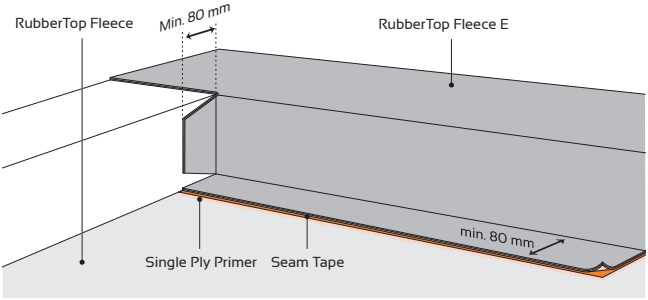
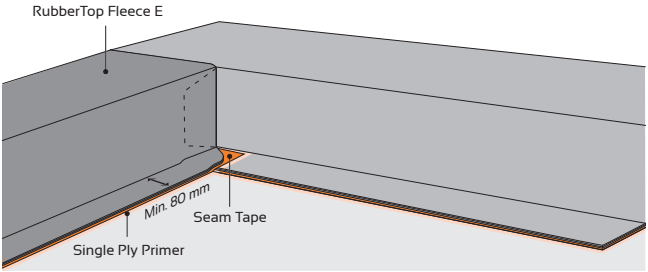
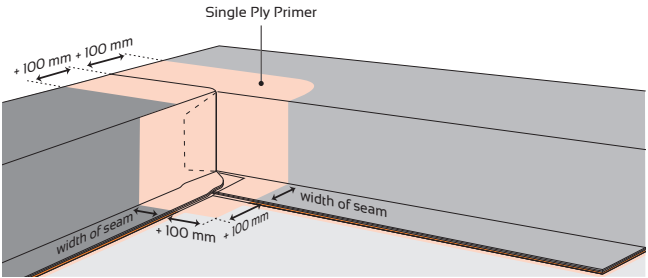

Figure 37



2. Apply Single-Ply Primer on the area as instructed.

Figure 38



3. Prepare a piece of Flashing Tape that can be folded in the corner as shown in the next figure. To ease installation we recommend cutting the release foil as shown.

i Remark: do not cut into the Flashing Tape.

Figure 39

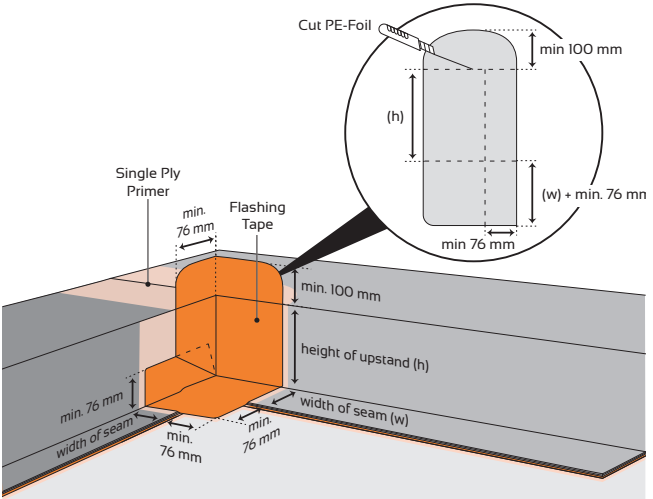

4. Follow the next steps for adhering the Flashing Tape, step by step. Do not forget to apply Single Ply Primer, respect open time and press piece by piece with a 40 mm silicone and a brass roller. Evenly distribute stresses while stretching the Flashing Tape.

i Note: Do not overstretch! The pattern in the Flashing Tape should remain visible.

Figure 40

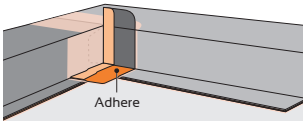

Figure 41

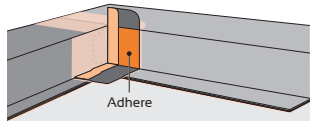

Figure 42

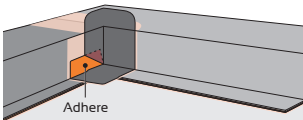

Figure 43

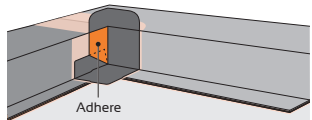

Figure 44

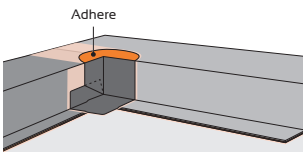
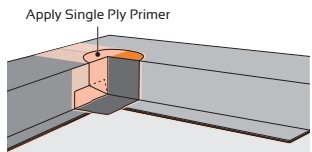

Figure 45



5. Prepare two additional Flashing patches as shown on the next figure. Apply Single Ply Primer, let it flash off and adhere the remaining Flashing pieces according to the picture below. Roll firmly afterwards without enclosing air with a 40 mm wide silicone

roller. Finally secure all seams with Sealant 5590.

Figure 46

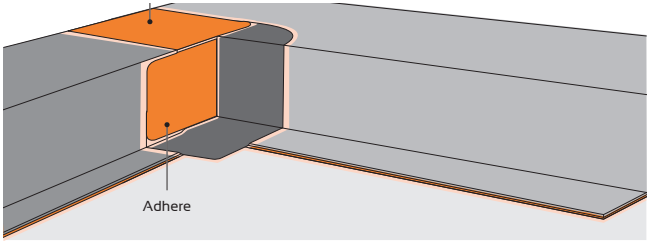

9.2 Internal Corners With Adhered Base Tie-In

When chosen for an adhered base tie-in design, the RubberTop Fleece membrane can be folded according to the drawings below. It is very important that all different layers stick to each other and to the substrate.

1. Fold back the membrane covering the upstands onto the horizontal roof surface as shown below.

Figure 47

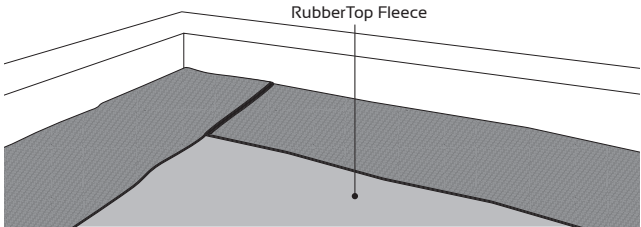

2. Apply a suitable adhesive on the surface of the upstand, roof edge and on the membrane. Adhere when flashed off. Pressure roll with a silicone pressure roller.

Figure 48

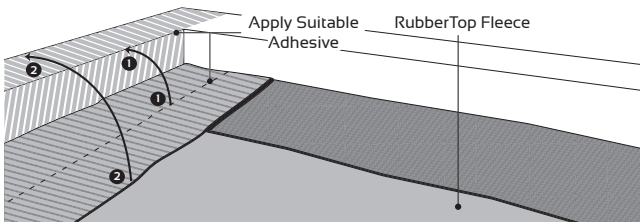

3. Measure the height of the upstand, mark the spot onto the membrane and cut the membrane as shown on the drawing below (1 + 2). Apply a suitable adhesive on the roof edge and let it flash off.

Figure 49

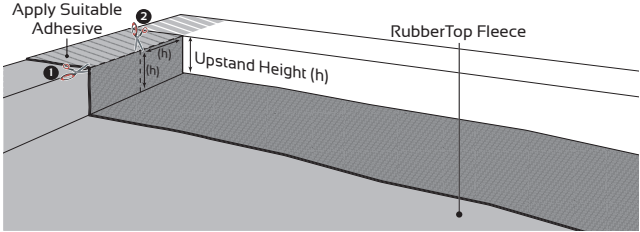

4. Mark the same spot onto the adjoining upstand. Adhere the horizontal piece on the parapet and pressure roll the membrane.

Figure 50

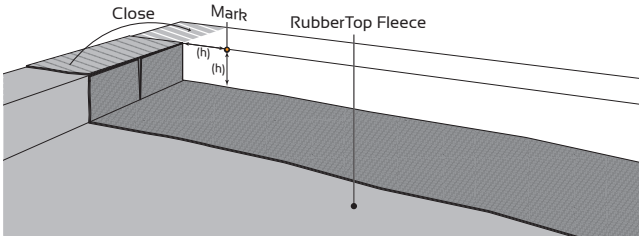

5. Apply adhesive on the upstand and the back of the EPDM. Let it flash off. Adhere the internal corner to the marked point. and adhere the EPDM onto the upstand towards the marked point. Adhere the remaining part of the internal corner and the horizontal piece on the parapet in the next step. Roll all adhered pieces with a silicone pressure roller.

Figure 51

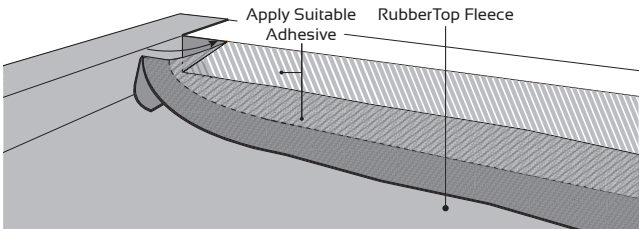
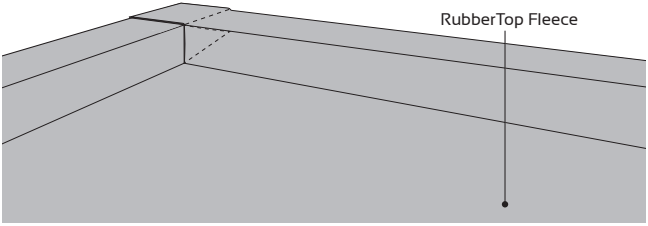

Figure 52



9.2.1. Flashing Tape Splicing Technique

After folding the inside corner, seal the corner with Flashing Tape as shown below. Follow all cold splicing instructions. Secure splices with Sealant 5590.

1. Apply Single Ply Primer and adhere a strip of Flashing Tape centered in the corner. The minimum width is 152 mm.

Figure 53

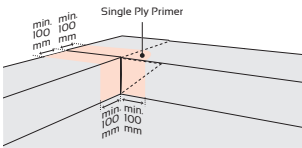
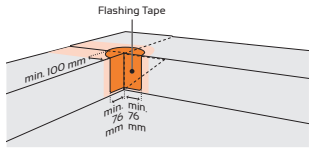

Figure 54



2. Apply Single Ply Primer on top of the Flashing Tape and let it flash off. Finally install Flashing Tape on the roof edge as shown below. Secure all seams with Sealant 5590.

Figure 55

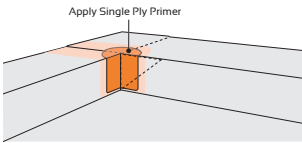
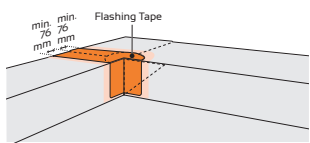

Figure 56



10 External Corners

General Instructions

The design of corners with a RubberTop Fleece depends on several parameters:

- Fixing method
- Upstand and base tie-in design

Important rules to be followed at all times:

- The membrane should be 100% clean. If not, use Cleaning Wash 9700.
- Follow all splicing instructions.
- All layers around the corner are properly fixed and adhered.
- Tension in the underlying layers is not allowed at all.

i Note: At all times RubberTop Fleece needs to be fixed mechanically at all roof edges. It is very important that the fleece backing is not in direct contact with water, because of a high risk for capillarity. All edges of RubberTop Fleece should be protected at all times!

i Note: In this chapter drawings are not provided with any base tie-in design. All instructions according to base tie-in have to be followed (chapter 7).

10.1 External Corners With Mechanically Fastened Base Tie-In

A separate EPDM strip to flash the upstands is used when a base tie-in is mechanically fastened. Depending on the type of the EPDM strip different techniques to flash the corner will be used.

10.1.1 Flashing Tape Splicing Technique

RubberTop Fleece E - RubberTop Upstand

1. Cut a strip RubberTop Fleece E or RubberTop EPDM as shown in the next figure. Adhere fully to the substrate. Keep the splicing areas free of adhesive and clean with Cleaning Wash 9700 when needed. The overlap for splicing with the roof membrane is at least 80 mm. The total overlap depends on the base tie-in design. Make the horizontal seam.

Figure 57

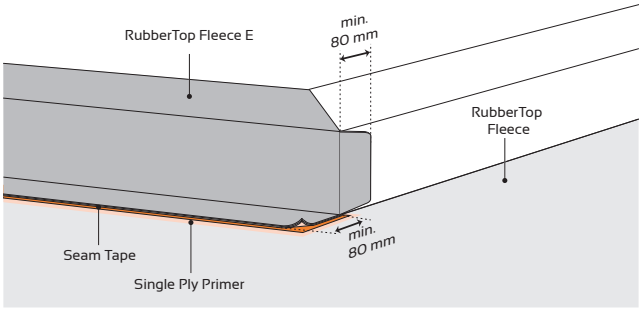

2. Install the adjoining EPDM strip and adhere as shown below.

Figure 58

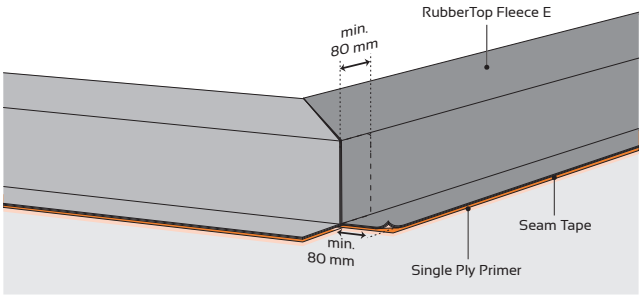

3. Prepare a Flashing Tape, cut the release foil to ease installation.

i Note: do not cut into the Flashing Tape.

Apply Single Ply Primer on the substrate. When flashed off, adhere the Flashing Tape and roll with a 40 mm wide silicone roller. Overlaps of Flashing Tape should be primed. When stretching the Flashing Tape on the corner ensure any stresses are distributed equally. The pattern in the Flashing Tape should remain visible. Roll with a 40 mm wide silicone roller.

Figure 59

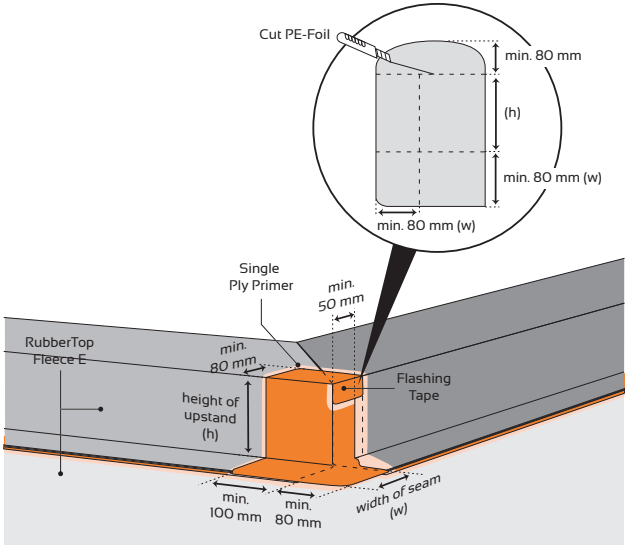

4. Follow the next steps for adhering the Flashing Tape, step by step. Do not forget to apply Single Ply Primer, respect open time and press piece by piece with a 40 mm silicone and a brass roller. Evenly distribute stresses while stretching the Flashing Tape.

i Note: Do not overstretch! The pattern in the Flashing Tape should remain visible.

Figure 60

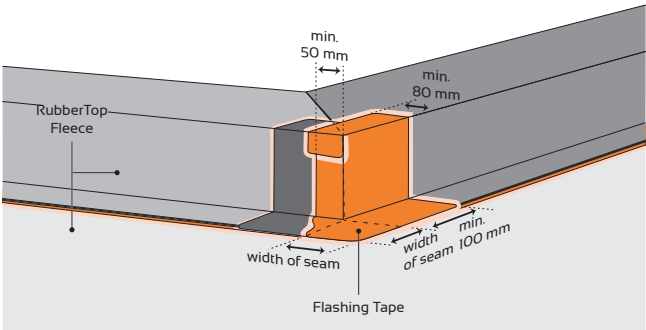
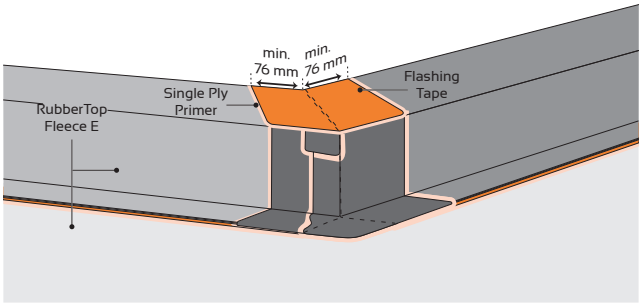

Figure 61



5. Finally secure all seams with Sealant 5590.

10.2 External Corners With Adhered Base Tie-In

When the base tie-in is secured with adhesives, the RubberTop Fleece membrane is cut as shown in the figure. Both sides of the corner shall be covered, taking into account all splicing instructions. Fully adhere the membrane to the substrate without any tension in the angles.

Splicing can be done with Flashing Tape splicing technique.

Figure 62

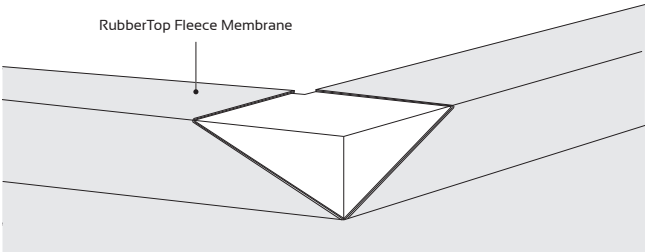

10.2.1. Flashing Tape Splicing Technique

1. Prepare a Flashing Tape and cut the release foil to ease installation. See figure 58.

i Note: do not cut into the Flashing Tape.

2. Apply Single Ply Primer on the substrate. When flashed off, adhere the Flashing Tape and roll with a 40 mm wide silicone roller. Overlaps of Flashing Tape should be primed. When stretching the Flashing Tape on the corner ensure any stresses are distributed equally.

Figure 63

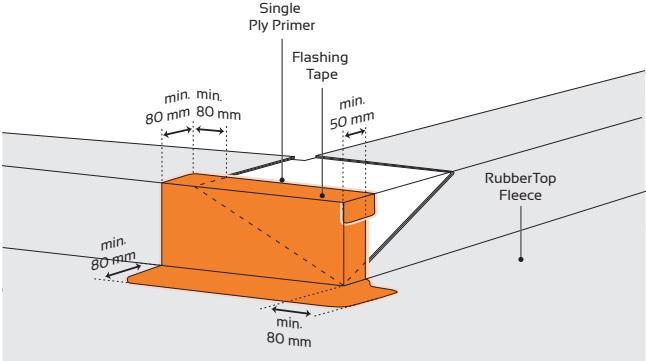

3. Follow the next steps for adhering the Flashing Tape, step by step. Do not forget to apply Single Ply Primer, respect open time and press piece by piece with a 40 mm silicone and a brass roller. Evenly distribute stresses while stretching the Flashing Tape. Secure all seams with Sealant 5590.

i Note: Do not overstretch! The pattern in the Flashing Tape should remain visible.

Figure 64

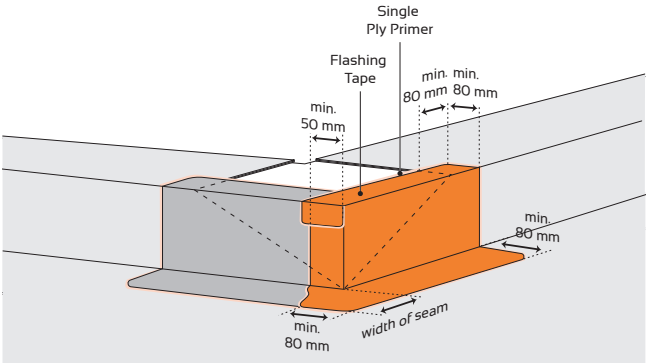
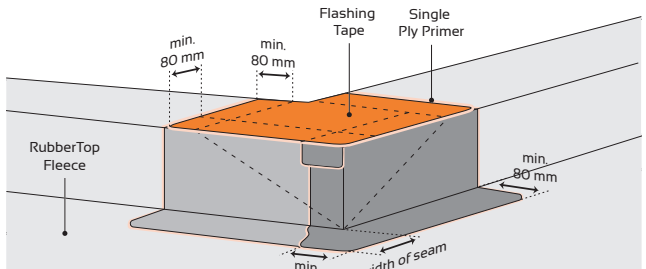

Figure 65



11 Drains

General Instructions

All water on a roof has to be drained. Do not underestimate the importance of a roof drain. Follow all national regulations at all times.

Important:

- Drains and scuppers must be firmly anchored in the substrate and must always consist of a hard material. The connection to the construction must be air and wind tight, to prevent convection and condensation. When passing a vapour barrier, do not forget to seal this connection airtight.
- The diameter of the drain/scupper is determined according to EN 12056-3. At all times, the maximum permissible water level on the roof must be taken into account. All drains must be installed with a minimum slope of 2% (horizontal drains).
- When a roof drain needs to be connected to a drain pipe, the connection shall be solid and vapour tight!
- RubberTop Fleece has to be fixed mechanically around all drains, to withstand tensions.
- When using HDPE drains with EPDM flap, only drains delivered by SealEco, with SealEco EPDM flaps shall be used. The use of other EPDM drains is not allowed.
- When using drains with a clamp ring (ex. Sita or equivalent), follow the instructions from the manufacturer.
- ❗ Note: The risk for capillarity with Fleece backed membranes is high. Avoid the fleece backing to be in contact with water.
- Adhesion to metal drains should be carried out with Flashing Tape.
- ❗ Note: It is very important that the metal is 100% clean! The installer will take full responsibility when using this type of drains.
- Lower the roof surface by at least 1 cm.
- To ensure proper splicing, position the drain as instructed. Drains shall not be installed close to parapets, skylights or other obstacles. A minimum distance has to be kept to allow proper splicing. If this is not the case, change it.

Figure 66

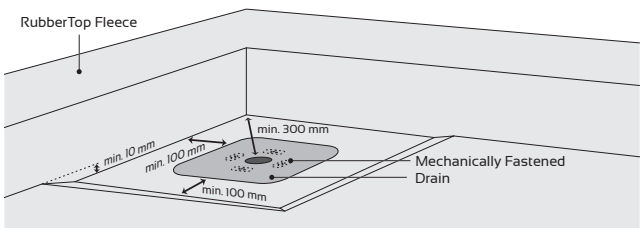

11.1 Drains With Splicing Tape Technique

SealEco provides different types of drains for seaming with cold splicing technique. Follow all splicing instructions.

Self-Adhesive HDPE Drain

Secure the horizontal roof surface with fasteners around the drain. Fix the drain solidly and air tight in the drain pipe. Splice the entire Cover Tape flap to the EPDM membrane following all splicing instructions. Secure all seams with Sealant 5590.

Figure 67

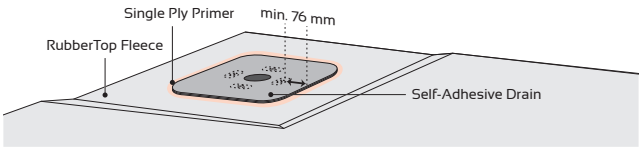

HDPE Drain With EPDM Flap

Fix the RubberTop fleece mechanically in the substrate with appropriate fasteners and washers. Connect the HDPE drain, ensuring it is water and air tight with the drainpipe. Adhere the flap with Contact Adhesive on the RubberTop Fleece membrane. Make a splice with Flashing Tape. Seal off with Sealant 5590.

Figure 68

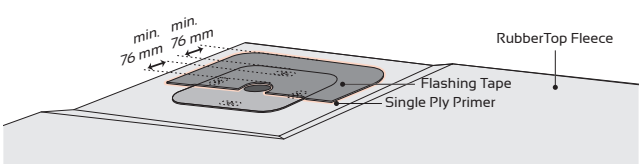
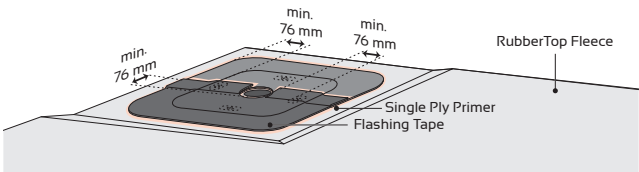

Figure 69



Metal Drains

Instructions:

1. Clean and degrease the metal thoroughly. Apply a bead of Sealant 5590 between the metal plate and the membrane. Apply this around the pipe keeping at least 50 mm from the edge of the plate.

2. Fix the metal with fasteners through the RubberTop Fleece membrane into the roof construction.

Figure 70

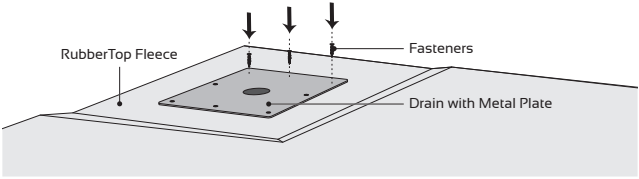

3. Make a splice with Flashing Tape and seal off with Sealant 5590.

Figure 71

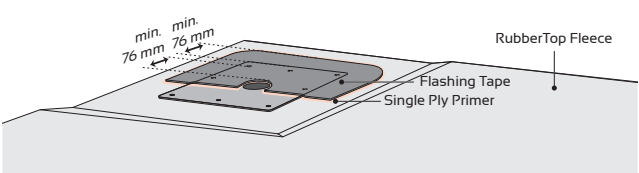
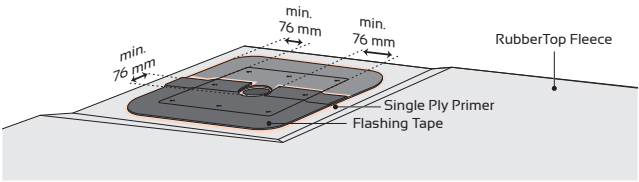

Figure 72



12 Pipe Penetrations

General Instructions

- All pipes shall be properly fixed in the substrate. Moving pipes might fatigue the Flashing Tape and cause cracking.
- When passing a vapour barrier, a vapour tight connection between the vapour barrier and the pipe is to be established to prevent convection and condensation.
- The maximum contact temperature of the pipe shall not exceed 80°C.
- When pipes are installed after installation of the RubberTop Fleece, the pipe has to be fastened mechanically through the membrane using an appropriate base plate.
- Fix the RubberTop Fleece according to the instructions. In case of adhered and ballasted roof build-ups the membrane has to be fully adhered or mechanically fastened around the pipe penetrations. (see chapter: 'Base Tie-In')
- The pipes shall be smooth and clean, especially when adhesion is required. Rusty surfaces have to be treated properly.
- The height of the EPDM strip on the pipe will be at least 150 mm above the final roof level.
- The minimum distance from a pipe to a parapet, skylight, corner, drain or other pipe is 300 mm. If this is not the case we advise you to move the pipe, otherwise proper splicing cannot be guaranteed.
- Never allow ponding water around a pipe penetration.
- A stainless pipe clamp has to be used at all times. Seal with Sealant 5590.

12.1 Flashing Tape Pipe Boot

There are two different ways of applying a Flashing Tape around a pipe. This depends on the external diameter of the pipe. It is not allowed to use these techniques for flexible pipe penetrations, cables and for pipes with a diameter < 40 mm. Follow all cold splicing instructions.

Small Pipes:

1. Prepare 2 identical Flashing pieces. Apply Single Ply Primer onto the surfaces. When flashed off, install both Flashing pieces onto the RubberTop Fleece membrane creating an upstand of min. 25 mm on the pipe. Roll the pieces firmly with a 40 mm wide silicone handroller and a brass corner roller. Avoid overstretching.

Figure 73

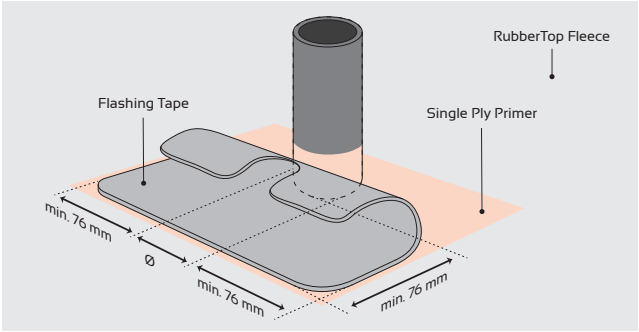
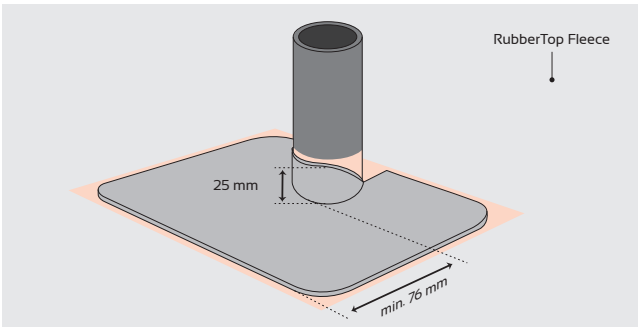
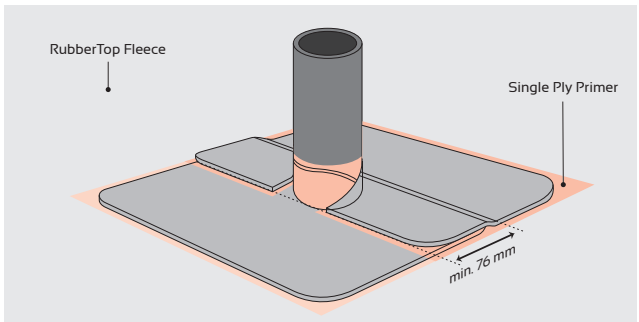

Figure 74



2. Make an overlap of minimum 76 mm. Apply Single Ply Primer. Let it flash off. Install the Flashing piece as shown below.

Figure 75



3. Apply Single Ply Primer onto the tube and the base Flashing. Cut a Flashing piece with following measurements:
 - Length = the circumference of the tube and add 76 mm.
 - Width = the height of the tube (min. 150 mm) and add 50 mm for adhering onto the base flashing.
4. Cut the PE protection foil at the base so the 50 mm zone can be folded back easily.

Figure 76

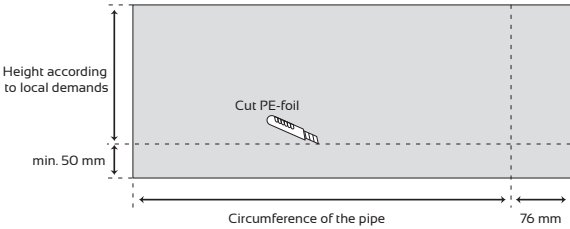

5. First adhere the flashing piece against the tube. Use your fingers to gradually adhere the flashing onto the base. Stretch the Flashing Tape towards the outside edge. Do not forget to prime the overlap before splicing.

Figure 77

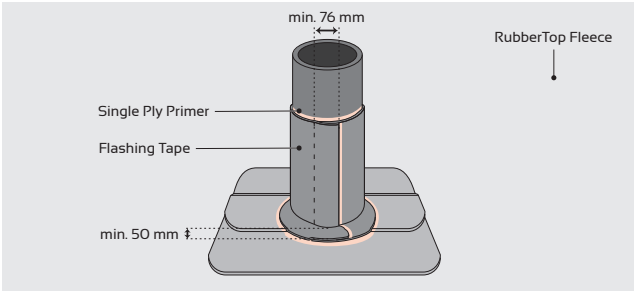

6. Secure all seams by applying Sealant 5590.

Big pipes:

1. Apply Single Ply Primer on the pipe and EPDM substrate to be covered.
2. Cut a piece with a length = circumference + 76 mm. Width = horizontal part to be covered + 25 mm.
3. When the primer is flashed off, install the Flashing without overstretching. Spread the stresses equally. Before splicing the overlap, apply Single Ply Primer and wait until flashed off. Roll firmly, don't enclose air.

Figure 78

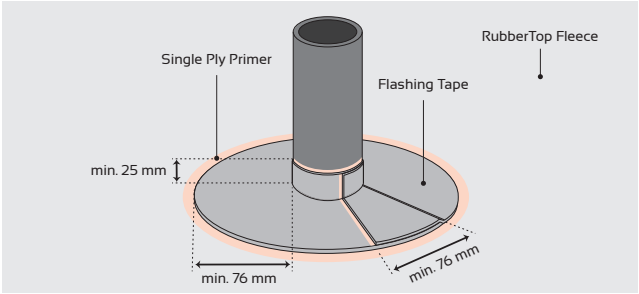

4. Cut a second piece, overlapping the horizontal Flashing base at least 50 mm. The height shall be 150 mm above the final roof level. Apply primer, wait until flashed off. Adhere the Flashing Tape. Apply Single Ply Primer on the overlap. Wait until flashed off, close and roll firmly. Finally seal off all splices and connections with Sealant 5590.

Figure 79

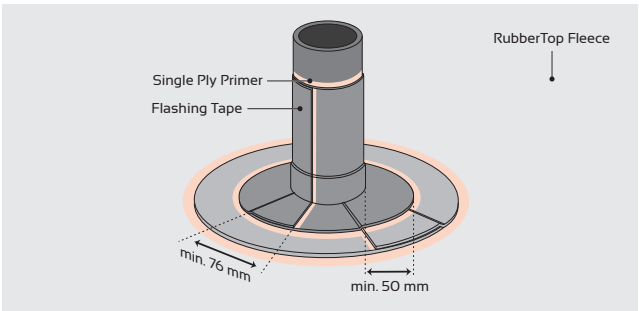

13 Roof Edge Details

General Instructions

In this chapter a few possible designs for termination of roof edges are shown. It is important to follow all local requirements.

Because of the complexity of drawings we sometimes omitted the different possibilities of base tie-in designs. It does not mean that they should be followed, on the contrary. Only the basic rules are shown.

Detail designs:

- Connections to walls
- Roof Edge Terminations
- Connections To Gutter
- Expansion Joints
- Green roof edge detail

i Note: At all times RubberTop Fleece needs to be fixed mechanically at all roof edges. It is very important that the fleece backing is not in direct contact with water, because of a high risk for capillarity. All edges of RubberTop Fleece should be protected at all times!

i Many details are sealed with Sealant 5590. These connections have to be checked at least twice a year and are not covered by any product guarantee because SealEco has neither control on the different substrates, neither on the application. It is the responsibility of the building owner to check these connections. We recommend that a maintenance contract is concluded between roofer and building owner to cover these risks.

Contact our Technical Department for more information.

13.1 Connections To Walls

Termination Bar

The use of a termination bar is allowed for ending RubberTop Fleece or RubberTop against a wall, only when there is no risk that water can penetrate behind the profile.

Figure 80

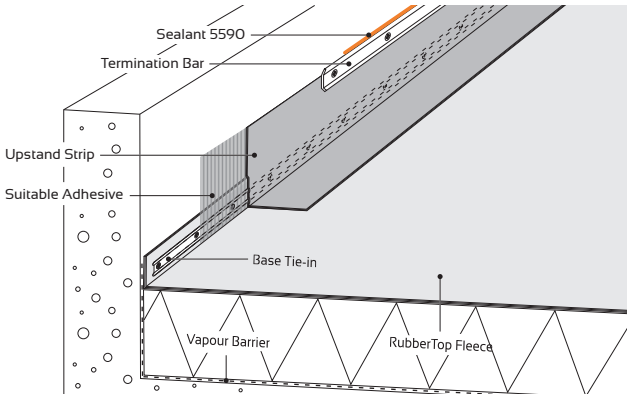

1. Cut the membrane in a straight line at the desired height. Adhere the membrane to the substrate as explained before. Fix the termination bar with appropriate fasteners used with watertight washers to prevent capillarity with the fleece backing. The distance in between the fasteners is maximum 200 mm and will be decreased when compression of the membrane is insufficient. Each profile shall be fastened at 25 mm from the end. Wall profiles shall never be bent around a corner. Always cut the profile. Two adjoining profiles will be spaced at 2 mm/m.
 2. Seal the profile with Sealant 5590. The sealant will adhere at least 10 mm on the profile and 15 mm on the wall. Smooth the sealant at an angle of 45°.
 3. When fixing vertically to a wall, the profile has to be sealed at both sides.
- i** Note: Never install profiles on top of existing waterproofing membranes, e.g. in refurbishments. Termination bars can only be used for connections to walls, concrete, etc.

Counterflashing

A termination profile will cause leakage if there are porous substrates, e.g. masonry, bricks, etc. A metal counterflashing shall be used e.g. RubberTop Flex.

Cut a chase into the wall a minimum of 25 mm depth, at the height required. This should be done prior to installing the RubberTop Fleece membrane. Remove all dust to assure proper adhesion. Adhere the membrane to the substrate. Fasten the membrane with a termination bar or with washers at least every 200 mm. Insert the counterflashing in the wall at least 25 mm. Fix with appropriate fasteners and seal with Sealant 5590 along the edge of the counterflashing.

Figure 81

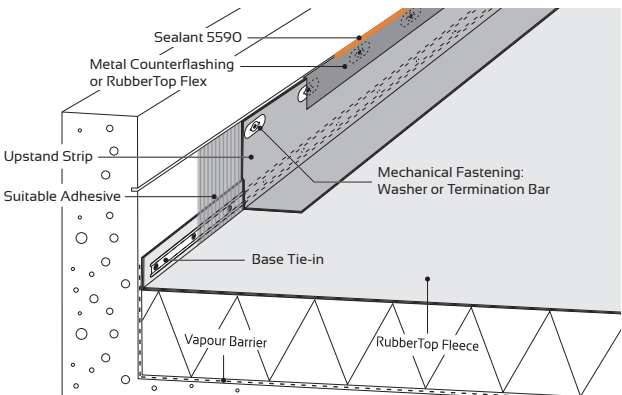

13.2 Roof Edge Terminations

Roof Edge Trim Profiles

Standard roof edge trims are available in aluminum and polyester. Follow these steps:

Adhere the RubberTop/RubberTop Fleece membrane as shown in the drawing. Fix the roof edge profile through the EPDM membrane at least every 300 mm. If there is high wind load, and unequal compression of the membrane, provide more fasteners. The building engineer can provide more information about wind load demands. Each profile shall be fastened at 25 mm from its end. Use corner pieces and never bend the profile around a corner. Two adjoining profiles will be spaced of 2 mm/m. Use proper connection pieces to align different profiles. Once the profiles are fixed, clean the profile and the EPDM with Cleaning Wash 9700. Apply Sealant 5590 as shown.

Figure 82

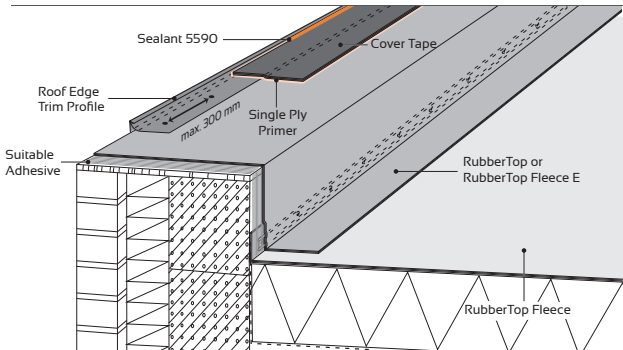

- i** Detailed instructions for splicing can be found in chapter 5.
- i** Note: Always perform an adhesion test, in particular when using PTFE coated trims. Because of continuous changes and variety of coatings used for profiles, it is impossible for SealEco to guarantee the adhesion on them. This is the responsibility of the roofer.

Bended Metal Roof Edge Termination

In several countries formed metal sheets are used for aesthetical solutions, fitting the building concept. When using zinc (treated in different ways), red copper, stainless steel, aluminum, etc. the metal sheets are either welded to each other or just overlapping.

Ask your supplier how to prevent capillarity when overlapping metal sheets. Because of thermal expansion there are different ways to

fix the sheets. The EPDM membrane however, should be fixed with fasteners at least every 200 mm. Connection between the metal and the EPDM is provided with a Cover Tape. Apply Single Ply Primer, and Flashing Tape for T-splices as explained in chapter 5 - splicing instructions.

Figure 83

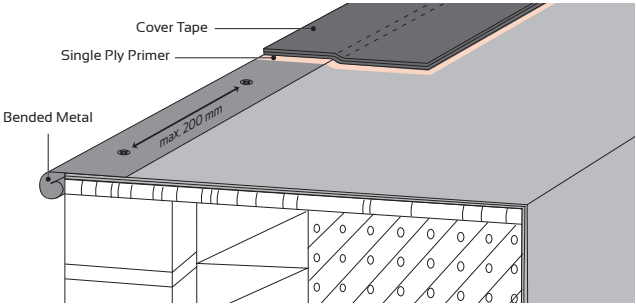

Metal Coping

A variety of different systems are available on the market.

Always take following instructions into consideration:

The RubberTop Fleece / RubberTop is fully adhered to the outside of the wall. Fix the membrane every 200 mm with appropriate fasteners, or clamps. Put a Seam Tape between the clamp and the membrane before tightening the fasteners. Most of the time the number of coping fasteners is insufficient for fixing of the membrane. Add washers and fasteners in between them.

i Note: Check that joints between copings are properly secured.

Figure 84

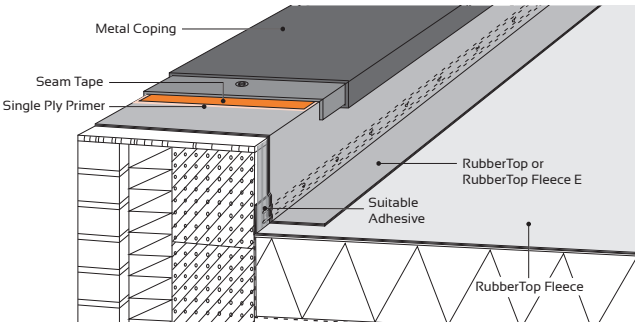

Coping Stone

Install the EPDM membrane across the top of the wall, 50 mm short of the outside face. Fully adhere the EPDM as described before. Lay the mortar bed from the rubber across to the outer brick wall to form a solid bed. Finally lay coping stones, ensuring that they give suitable coverage over the wall. A flexible joint between the façade and the copingstone has to be made with appropriate sealant.

i Note: Use only coping stones with drip edges!

Figure 85

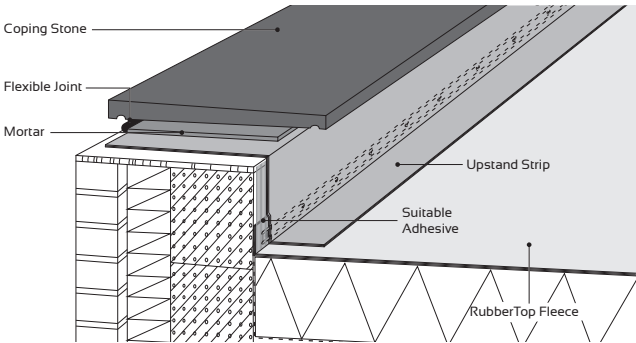

13.3 Connections To Gutter

At all times, the EPDM membrane has to be cut when water runs from a roof into a gutter. The solutions below show the principle. Avoid ponding water by respecting the advised roof slope of 2°.

External Gutter With A Cover Tape

Fully adhere the EPDM membrane at the roof edge. Fix the formed metal sheet through the EPDM membrane at least every 200 mm. Connect the metal sheets in accordance with manufacturer instructions. Clean the metal with Cleaning Wash 9700. Apply Single Ply Primer and Cover Tape.

All T-splices have to be sealed with Flashing Tape. Secure with Sealant 5590. Detailed instructions for splicing can be found in chapter 5.

Figure 86

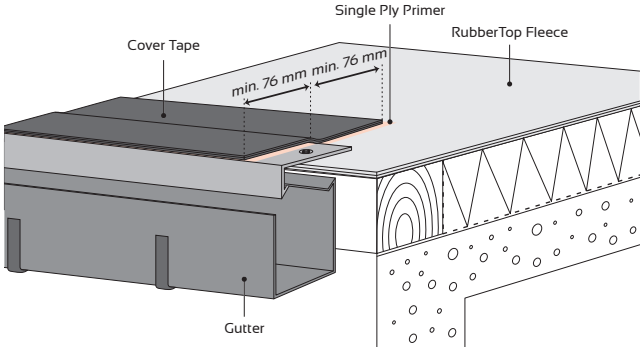

Wooden, Concrete Gutters With Cover Tape

First adhere a separate RubberTop/RubberTop Fleece EPDM membrane in the gutter up to min. 150 mm on the horizontal roof surface. Install the RubberTop roof membrane with an overlap of at least the width of the washer + 20 mm. Fasten both membranes at the same time every 200 mm.

Splice the seam with a Cover Tape as explained in chapter 5.

Figure 87

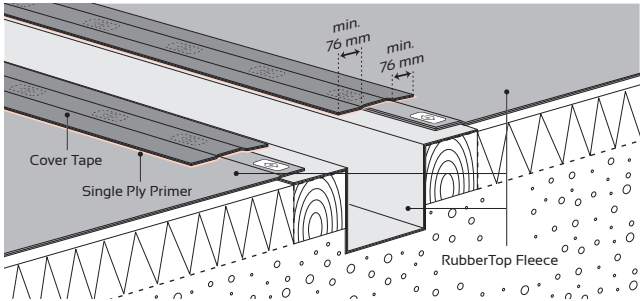

13.4 Expansion Joints

The design of expansion joints with RubberTop Fleece membranes depends on the size and the location. The size, the place and the number will be calculated by building engineer. We show only a few possible ways to handle this roofing detail.

Thanks to the properties of EPDM, dealing with expansion joints is simple. EPDM has extremely good elasticity and ageing properties. Fatigue tests prove that EPDM has unique properties to cope with non-stop tensions around expansion joints. However never stress the membrane more than 25%.

We make a distinction between loose laid and adhered or mechanically fixed membranes.

Loose Laid / Ballasted Roofs

When using RubberTop Fleece as a ballasted roofing system, mostly also the insulation will be loose laid.

In that case just fix a galvanised, coated or stainless steel metal plate in the substrate. The plate is fully covering the expansion joint and is properly fixed in the construction. Vapour barrier needs to be fixed as prescribed by the manufacturer, engineer, or according to local regulations.

Figure 88

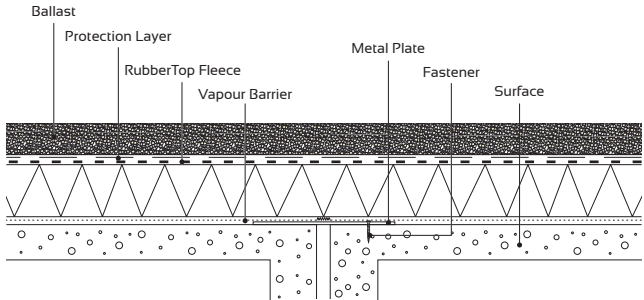

Adhered And Mechanically Fastened Roofs

When RubberTop Fleece is adhered or fixed mechanically, stresses should be handled locally, without putting any additional load on the attachment of the membrane.

A solution is to use a separate upstand of RubberTop membrane. Different splicing methods are explained in chapter 5.

Figure 89

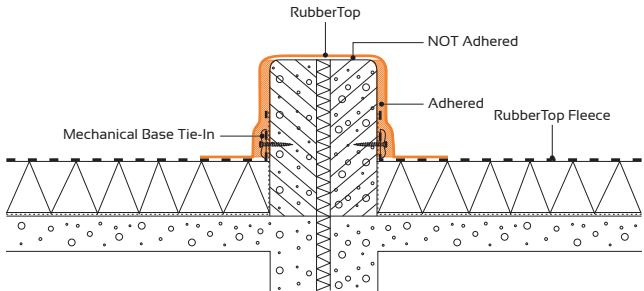

For more solutions, contact our technical department.

13.5 Green Roof Edge Detail

Use this principle for all roof edge solutions where water has to run into a gutter:

- Fix a shaped metal profile, through the RubberTop Fleece EPDM (see chapter - gutters).
- Clean the metal plate and adhere Seam Tape to the dripping plate
- Install the green roof edge profile onto the tape, and fasten at least every 200 mm in the substrate through the EPDM membrane. The Seam Tape should be equally compressed over the entire length. The connections between dripping plates and those of the green roof edge profile should be distanced at least 200 mm.
- Seal the RubberTop Fleece to the profile with cold Tape splicing technique. Degrease the profile with Cleaning Wash 9700 prior to splicing. Apply Single Ply Primer and use a Cover Tape of at least 152 mm.
- Seal with Sealant 5590.

Figure 90

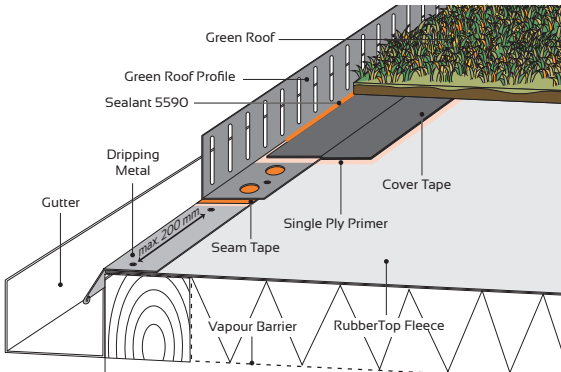

- i** Note: Contact our Technical Department when specific details have to be sealed, or when alternative profiles are proposed by the green roof contractor.

14 Supervision And Maintenance

The RubberTop Fleece membrane is maintenance free and has excellent durability without any sort of treatment.

The supervision and maintenance of a roof is the responsibility of the building owner. Experience has taught us however that generally roofs are only inspected when irregularities such as leakages or blocked drains are discovered.

Therefore it is imperative to check the roof at least twice a year, after winter and after the leaves have fallen. As well as after every storm or exceptional precipitation. SealEco recommends agreeing to a maintenance contract with a recognised roofer for this. During the inspection the function of the roof is evaluated and deviations should be handled. Details in the roof are of higher importance than the surface and should be carefully examined: skylights, ventilation, curbs, connections to walls, drains, and pipe penetrations.

Check all sealants, because they are not part of the product guarantee of the roofing system.

To maintain good functionality of the roof it should be cleaned on a regular basis. All foreign objects such as contamination, vegetation and leaves should be removed. It is of extra importance to keep the drainage free so that they can function as intended.

RubberTop Fleece should never be exposed to aromatic hydrocarbons such as oil, diesel or fat. If these type of chemicals should leak to the roof they must be removed immediately or they will damage the membrane. Regular walking on the membrane should be kept to a minimum. If there is regular traffic this should be considered in the design by adding walkways or pavers in that area. If snow or ice needs to be removed from a roof, shoveling must be done carefully, leaving minimum 5cm on the roof surface to make sure that the membrane isn't damaged by the work.

Green roofs need extra care. A maintenance contract or service agreement is highly recommended. Advise the green roof supplier on the use of fertilisers.

Leakage

If leakage into a building is detected there can be several reasons and a careful investigation must be done. Leakages do not necessarily mean that there is a problem with the RubberTop Fleece membrane.

Finding the problem includes considering:

- Mechanical damage of the membrane
- When did the leakage first show?
- Weather conditions prior to leakage?
- Clogged drains or bad piping?
- Bad roof windows or ventilation shafts?
- Bad cladding in connection to the roof or the facade?
- Condensation from within due to wrong construction?
- Under what conditions does the leakage start/stop or does it constantly leak?
- Point of leakage in comparison to the slope of the roof (drained area)?

SealEco has well developed techniques for finding leakages and can assist when the origin of the leakage is hard to find.



We make
waterproofing
easy

Your RubberTop Fleece dealer:

JANUARI 2021

For more information, visit www.sealeco.com